

Series AF2



AVENTICS™ Series AF2



Flow sensor, IO-Link, Series AF2

- 2 analog outputs, 2 switch outputs, 1 frequency output, 1 pulse output, IO-Link, With mounting
- Flow measuring principle: calorimetric
- Qn min. 5 l/min
- Qn max. 1590 l/min
- Electrical connection Plug, M12x1, 5-pin

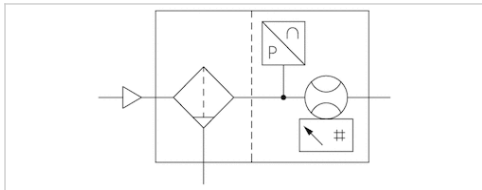

Certificates	CE declaration of conformity, RoHS
Working pressure min./max.	0 ... 16 bar
Ambient temperature min./max.	-20 ... 60 °C
Medium temperature min./max.	-20 ... 60 °C
Medium	Compressed air, Argon, Nitrogen, Helium, Carbon dioxide
filter porosity	5 µm
Display	OLED
Flow display unit	l/sec, l/min, m³/min, m³/h, ft³/s, m³/min
Pressure display unit	bar, psi
Temperature display unit	°C, °F
DC operating voltage min.	17 V DC
DC operating voltage max.	30 V DC
Max. power consumption *)	175 mA
Response time	10 ms
Protection class	IP65, IP67 according to IEC 60529
Short circuit resistance	short circuit resistant
Shock resistance max.	30 g, 11 ms
Vibration resistance	1 g (10 - 2000 Hz) IEC 60068 - 2-6
Reproducibility	± 1.5% of the measured value
Weight	1,23 kg
*)	Current consumption without load The delivered product may vary from that in the illustration.

Technical data

Part No.	for series	Compressed air connection	Nominal flow Qn	Nominal flow Qn	Nominal flow Qn
			Min., standard	Max., standard	Min., extended
R412026834	AS2	G 3/8	5 l/min	1060 l/min	1060 l/min

Part No.	Nominal flow Qn
	Max., extended
R412026834	1590 l/min

Standard measurement range for flow measurement: compressed air 0.5 ... 100 m/s, extended measurement range: compressed air >100 ... 150 m/s, in accordance with ISO 8778, Flow display range: 0 ... 3180 l/min

Technical information

The pressure dew point must be at least 15 °C under ambient and medium temperature and may not exceed 3 °C .
The protection class is only ensured when the plug is mounted properly. For detailed information, see operating instructions.
The device is designed to be installed in AS series air preparation units or to be fitted as a stand-alone device using a W05 block assembly kit.
Liquid oil or water must be separated via prefiltering. If it is not separated sufficiently, drifting may result.
Precision- Standard measurement range: $\pm 3\%$ of measured value, + 0.3% of final value- Extended measurement range: $\pm 8\%$ of measured value, + 1% of final value
The IO-Link device description (IODD) for the AF2 flow rate sensor is available for download in the Media Center.

Technical information

Material	
Housing	Polyamide, Polycarbonate
Seals	Fluorocautchouc

Dimensions

Dimensions in mm

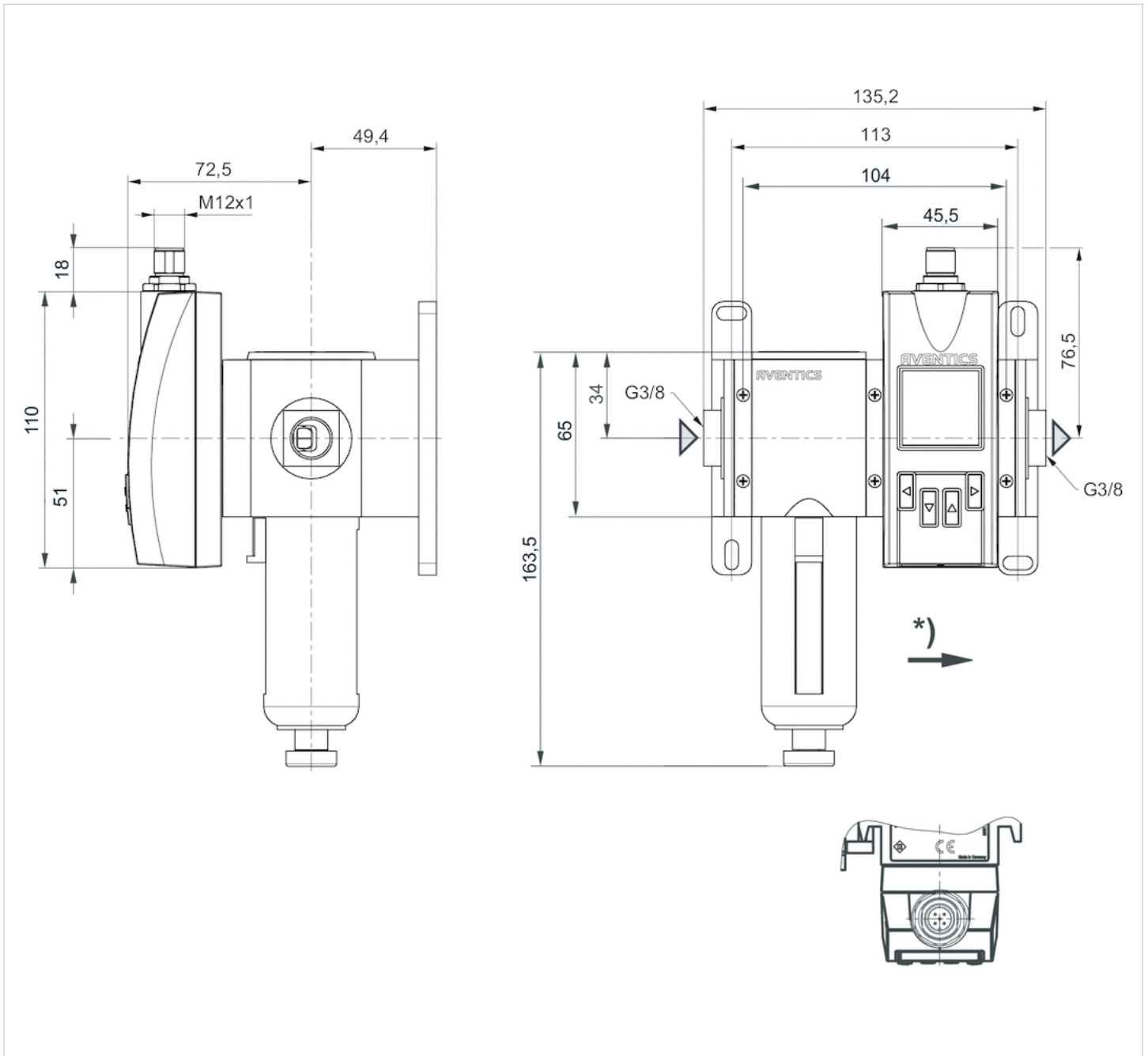

* Flow direction

Pin assignments

Pin assignments, M12x1, 5-pin

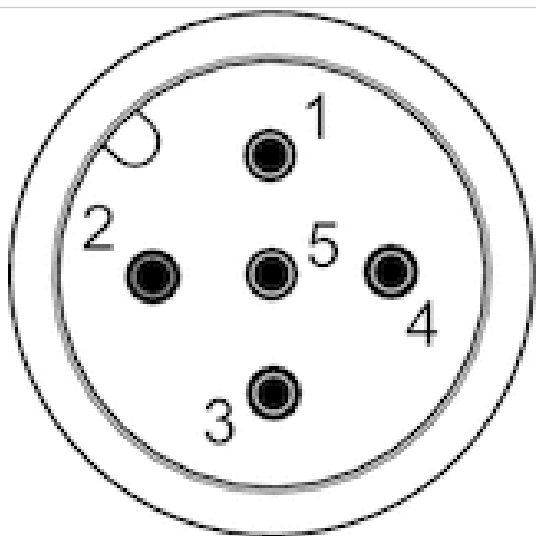

Pin	1	2	3
Allocation	L+	QA (output 4 ... 20 mA)	m = mass
	4	5	
	C/Q1 (IO-Link/switch output)	Analog output 4 ... 20 mA	

Flow sensor, IO-Link, Series AF2

- 2 analog outputs, 2 switch outputs, 1 frequency output, 1 pulse output, IO-Link, With mounting
- Flow measuring principle: calorimetric
- Qn min. 8 l/min
- Qn max. 2445 l/min
- Electrical connection Plug, M12x1, 5-pin

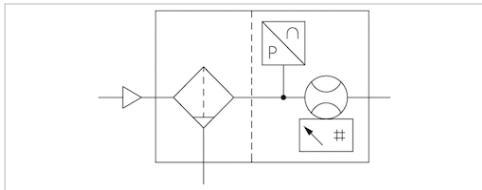

Certificates	CE declaration of conformity, RoHS
Working pressure min./max.	0 ... 16 bar
Ambient temperature min./max.	-20 ... 60 °C
Medium temperature min./max.	-20 ... 60 °C
Medium	Compressed air, Argon, Nitrogen, Helium, Carbon dioxide
filter porosity	5 µm
Display	OLED
Flow display unit	l/sec, l/min, m³/min, m³/h, ft³/s, m³/min
Pressure display unit	bar, psi
Temperature display unit	°C, °F
DC operating voltage min.	17 V DC
DC operating voltage max.	30 V DC
Max. power consumption *)	175 mA
Response time	10 ms
Protection class	IP65, IP67 according to IEC 60529
Short circuit resistance	short circuit resistant
Shock resistance max.	30 g, 11 ms
Vibration resistance	1 g (10 - 2000 Hz) IEC 60068 - 2-6
Reproducibility	± 1.5% of the measured value
Weight	1,97 kg
*)	Current consumption without load

Technical data

Part No.	for series	Compressed air connection	Nominal flow Qn	Nominal flow Qn	Nominal flow Qn
			Min., standard	Max., standard	Min., extended
R412026835	AS3	G 1/2	8 l/min	1630 l/min	1630 l/min

Part No.	Nominal flow Qn
	Max., extended
R412026835	2445 l/min

Standard measurement range for flow measurement: compressed air 0.5 ... 100 m/s, extended measurement range: compressed air >100 ... 150 m/s, in accordance with ISO 8778, Flow display range: 0 ... 4890 l/min

Technical information

The pressure dew point must be at least 15 °C under ambient and medium temperature and may not exceed 3 °C .
 The protection class is only ensured when the plug is mounted properly. For detailed information, see operating instructions.
 The device is designed to be installed in AS series air preparation units or to be fitted as a stand-alone device using a W05 block assembly kit.
 Liquid oil or water must be separated via prefiltering. If it is not separated sufficiently, drifting may result.
 Precision- Standard measurement range: ±3% of measured value, + 0.3% of final value- Extended measurement range: ±8% of measured value, + 1% of final value
 The IO-Link device description (IODD) for the AF2 flow rate sensor is available for download in the Media Center.

Technical information

Material	
Housing	Polyamide, Polycarbonate
Seals	Fluorocautchouc

Dimensions

Dimensions in mm

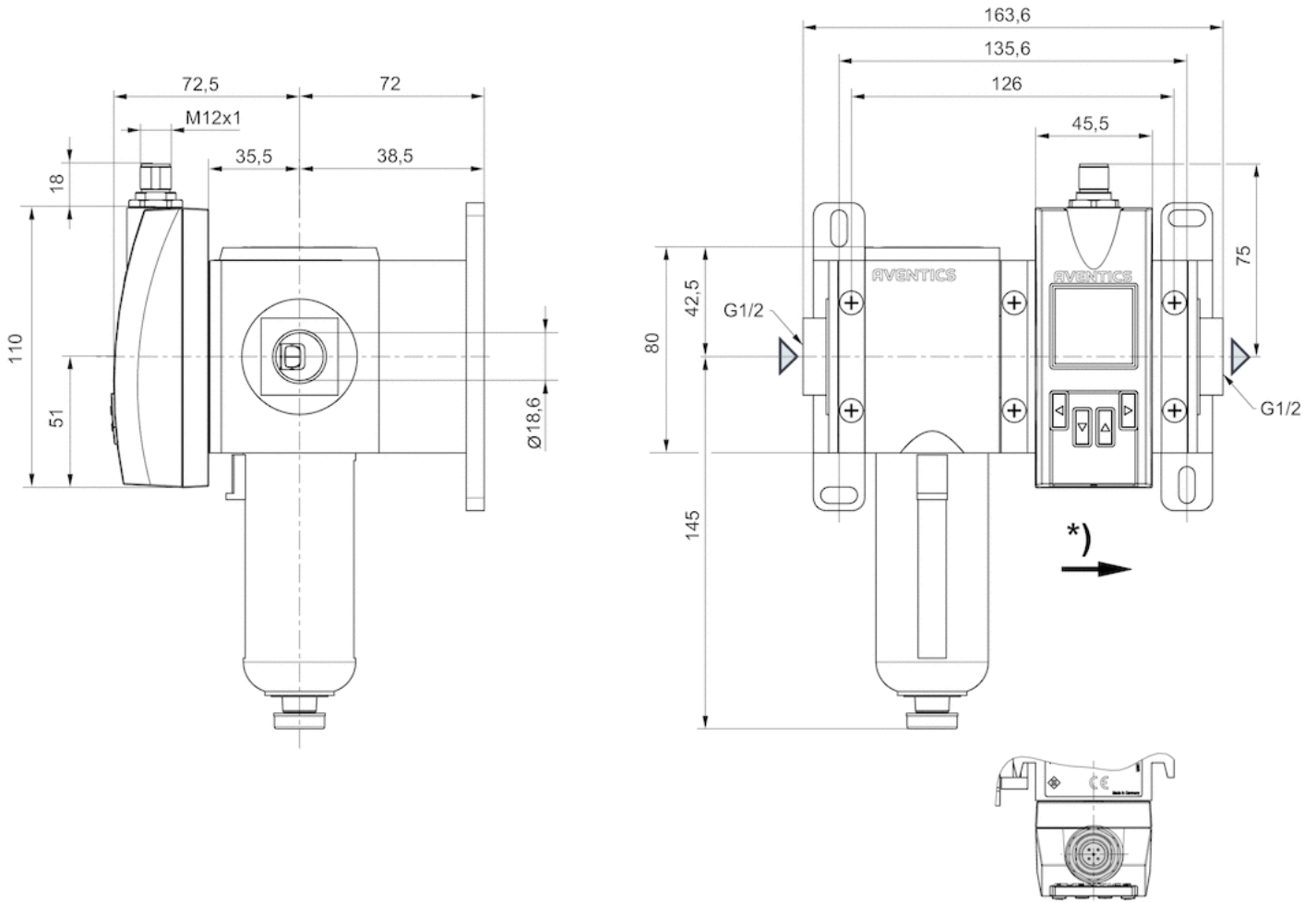

* Flow direction

Pin assignments

Pin assignments, M12x1, 5-pin

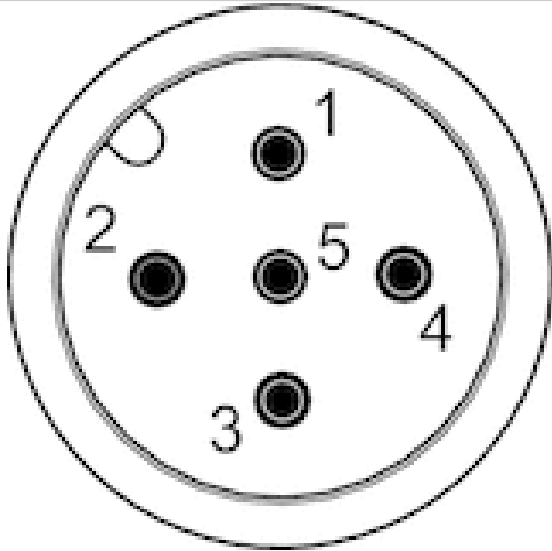

Pin	1	2	3
Allocation	L+	QA (output 4 ... 20 mA)	m = mass
	4	5	
	C/Q1 (IO-Link/switch output)		Analog output 4 ... 20 mA

Flow sensor, IO-Link, Series AF2

- 2 analog outputs, 2 switch outputs, 1 frequency output, 1 pulse output, IO-Link, With mounting
- Flow measuring principle: calorimetric
- Qn min. 22 l/min
- Qn max. 6490 l/min
- Electrical connection Plug, M12x1, 5-pin

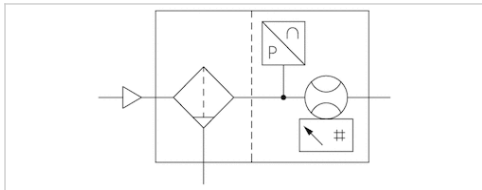

Certificates	CE declaration of conformity, RoHS
Working pressure min./max.	0 ... 16 bar
Ambient temperature min./max.	-20 ... 60 °C
Medium temperature min./max.	-20 ... 60 °C
Medium	Compressed air, Argon, Nitrogen, Helium, Carbon dioxide
filter porosity	5 µm
Display	OLED
Flow display unit	l/sec, l/min, m³/min, m³/h, ft³/s, m³/min
Pressure display unit	bar, psi
Temperature display unit	°C, °F
DC operating voltage min.	17 V DC
DC operating voltage max.	30 V DC
Max. power consumption *)	175 mA
Response time	10 ms
Protection class	IP65, IP67 according to IEC 60529
Short circuit resistance	short circuit resistant
Shock resistance max.	30 g, 11 ms
Vibration resistance	1 g (10 - 2000 Hz) IEC 60068 - 2-6
Reproducibility	± 1.5% of the measured value
Weight	2,82 kg
*)	Current consumption without load The delivered product may vary from that in the illustration.

Technical data

Part No.	for series	Compressed air connection	Nominal flow Qn	Nominal flow Qn	Nominal flow Qn
			Min., standard	Max., standard	Min., extended
R412026836	AS5	G 1	22 l/min	4326 l/min	4326 l/min

Part No.	Nominal flow Qn
	Max., extended
R412026836	6490 l/min

Standard measurement range for flow measurement: compressed air 0.5 ... 100 m/s, extended measurement range: compressed air >100 ... 150 m/s, in accordance with ISO 8778, Flow display range: 0 ... 12980 l/min

Technical information

The pressure dew point must be at least 15 °C under ambient and medium temperature and may not exceed 3 °C .
The protection class is only ensured when the plug is mounted properly. For detailed information, see operating instructions.
The device is designed to be installed in AS series air preparation units or to be fitted as a stand-alone device using a W05 block assembly kit.

Liquid oil or water must be separated via prefiltering. If it is not separated sufficiently, drifting may result.

Precision- Standard measurement range: $\pm 3\%$ of measured value, + 0.3% of final value- Extended measurement range: $\pm 8\%$ of measured value, + 1% of final value

The IO-Link device description (IODD) for the AF2 flow rate sensor is available for download in the Media Center.

Technical information

Material	
Housing	Polyamide, Polycarbonate
Seals	Fluorocautchouc

Dimensions

Dimensions in mm

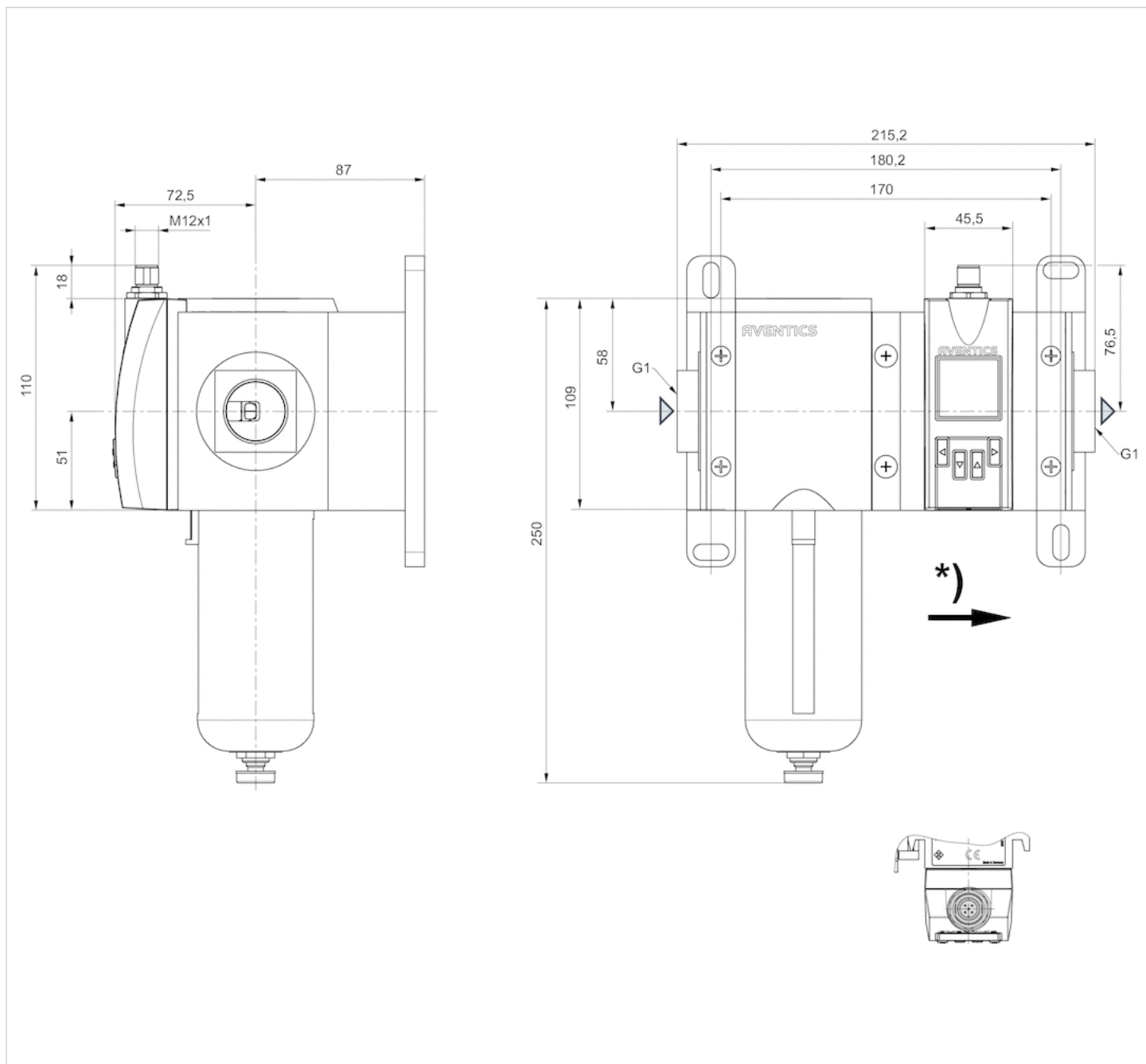

* Flow direction

Pin assignments

Pin assignments, M12x1, 5-pin

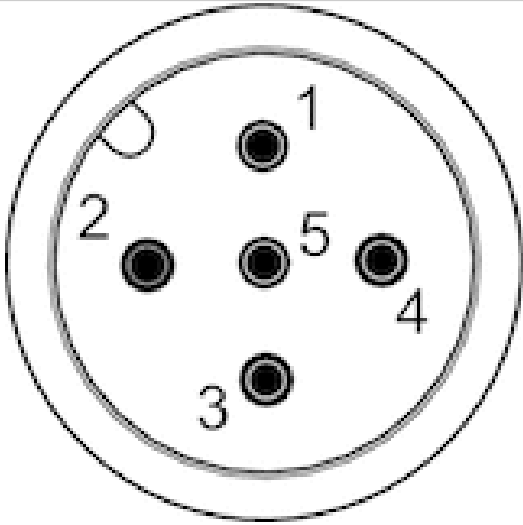

Pin	1	2	3
Allocation	L+	QA (output 4 ... 20 mA)	m = mass
	4	5	
	C/Q1 (IO-Link/switch output)	Analog output 4 ... 20 mA	

Flow sensor, Ethernet, Series AF2

- Ethernet, With mounting
- Flow measuring principle: calorimetric
- Qn min. 5 l/min
- Qn max. 1590 l/min
- Electrical connection Plug, M12x1, 8-pin

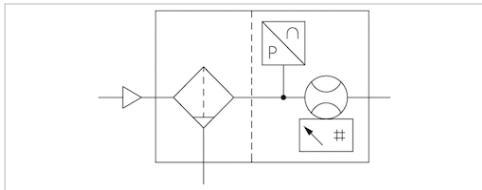

Certificates	CE declaration of conformity, RoHS
Working pressure min./max.	0 ... 16 bar
Ambient temperature min./max.	-20 ... 60 °C
Medium temperature min./max.	-20 ... 60 °C
Medium	Compressed air, Argon, Nitrogen, Helium, Carbon dioxide
filter porosity	5 µm
Display	OLED
Flow display unit	l/sec, l/min, m³/min, m³/h, ft³/s, m³/min
Pressure display unit	bar, psi
Temperature display unit	°C, °F
DC operating voltage min.	36 V DC
DC operating voltage max.	57 V DC
Power consumption max.	5 W
Response time	10 ms
Protection class	IP65, IP67 according to IEC 60529
Shock resistance max.	30 g, 11 ms
Vibration resistance	1 g (10 - 2000 Hz) IEC 60068 - 2-6
Reproducibility	± 1.5% of the measured value
Weight	1,23 kg
*)	The delivered product may vary from that in the illustration.

Technical data

Part No.	for series	Compressed air connection	Nominal flow Qn	
			Min., standard	Max., standard
R412026837	AS2	G 3/8	5 l/min	1060 l/min
			Nominal flow Qn	
			Max., extended	
R412026837			1590 l/min	

Standard measurement range for flow measurement: compressed air 0.5 ... 100 m/s, extended measurement range: compressed air >100 ... 150 m/s, in accordance with ISO 8778, Flow display range: 0 ... 3180 l/min

Technical information

The pressure dew point must be at least 15 °C under ambient and medium temperature and may not exceed 3 °C .
The protection class is only ensured when the plug is mounted properly. For detailed information, see operating instructions.
The device is designed to be installed in AS series air preparation units or to be fitted as a stand-alone device using a W05 block assembly kit.
Liquid oil or water must be separated via prefiltering. If it is not separated sufficiently, drifting may result.
Precision- Standard measurement range: $\pm 3\%$ of measured value, + 0.3% of final value- Extended measurement range: $\pm 8\%$ of measured value, + 1% of final value

Technical information

Material	
Housing	Polyamide, Polycarbonate
Seals	Fluorocaoutchouc

Dimensions

Dimensions in mm

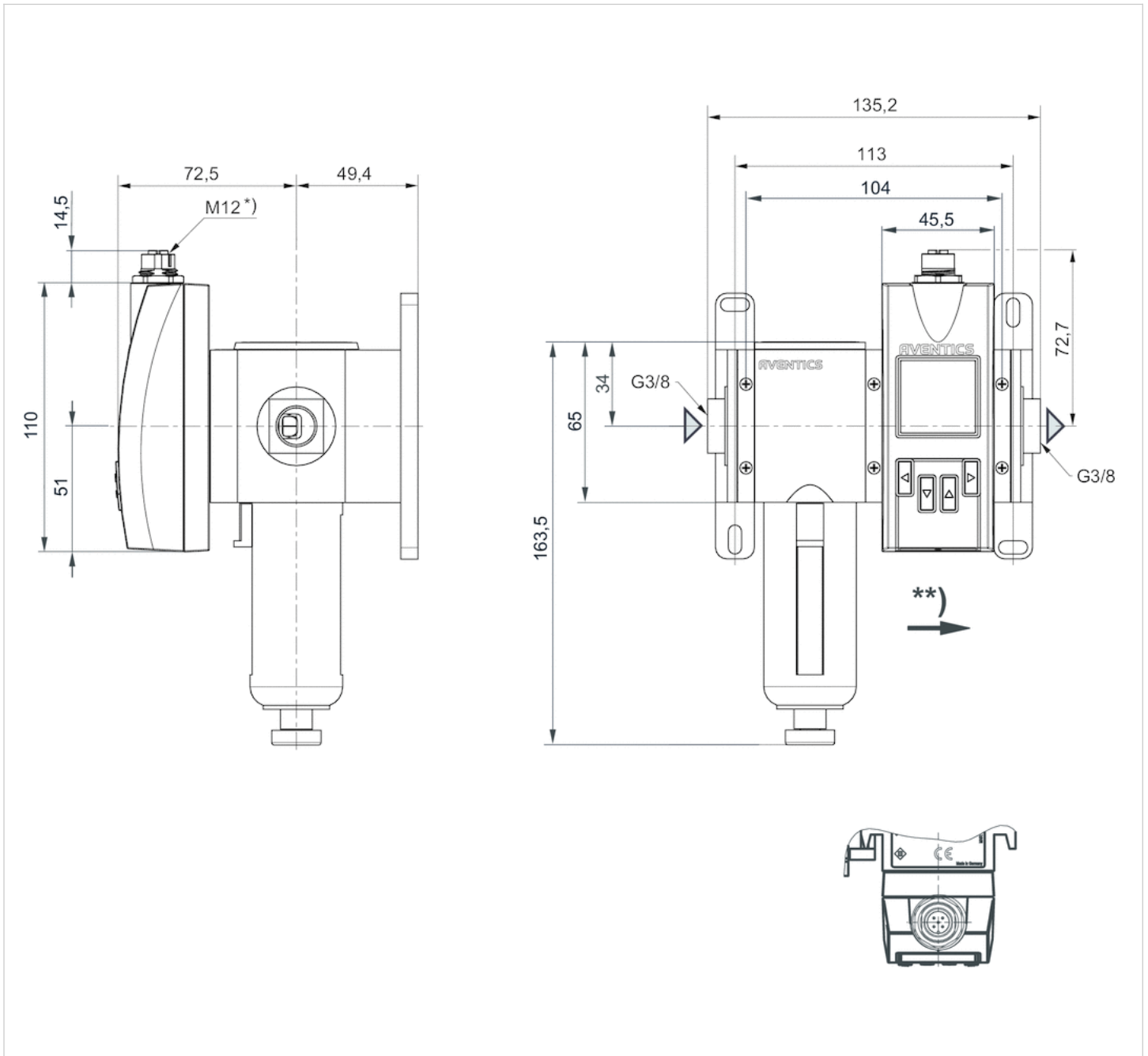

* Internal thread

** Flow direction

Pin assignments

Pin assignments, M12, X-coded

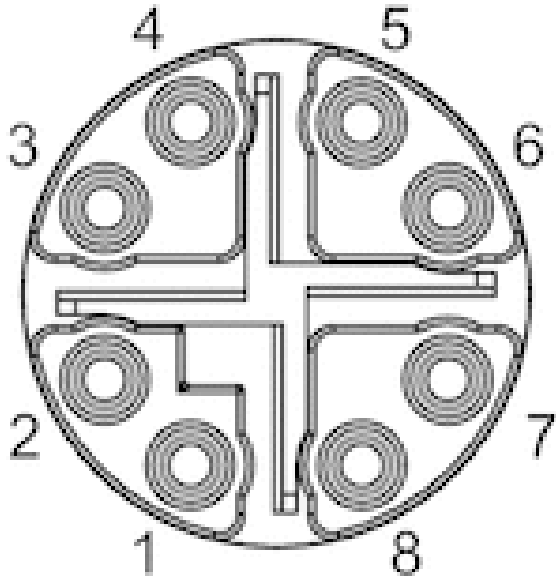

Pin	1	2	3	4	7	8	5
Color	WH / OG	OG	WH / GN	GN	WH / BU	BU	WH / BN
Function	TX(+) + POE	TX(-) + POE	RX(+) - POE	RX(-) - POE	POE+	POE+	POE-
			6				
			BN				
			POE-				

Flow sensor, Ethernet, Series AF2

- Ethernet, With mounting
- Flow measuring principle: calorimetric
- Qn min. 8 l/min
- Qn max. 2445 l/min
- Electrical connection Plug, M12x1, 8-pin

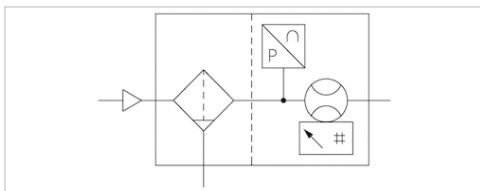

Certificates	CE declaration of conformity, RoHS
Working pressure min./max.	0 ... 16 bar
Ambient temperature min./max.	-20 ... 60 °C
Medium temperature min./max.	-20 ... 60 °C
Medium	Compressed air, Argon, Nitrogen, Helium, Carbon dioxide
filter porosity	5 µm
Display	OLED
Flow display unit	l/sec, l/min, m³/min, m³/h, ft³/s, m³/min
Pressure display unit	bar, psi
Temperature display unit	°C, °F
DC operating voltage min.	36 V DC
DC operating voltage max.	57 V DC
Power consumption max.	5 W
Response time	10 ms
Protection class	IP65, IP67 according to IEC 60529
Shock resistance max.	30 g, 11 ms
Vibration resistance	1 g (10 - 2000 Hz) IEC 60068 - 2-6
Reproducibility	± 1.5% of the measured value
Weight	1,97 kg

Technical data

Part No.	for series	Compressed air connection	Nominal flow Qn	
			Min., standard	Max., standard
R412026838	AS3	G 1/2	8 l/min	1630 l/min

Part No.	Nominal flow Qn
	Max., extended
R412026838	2445 l/min

Standard measurement range for flow measurement: compressed air 0.5 ... 100 m/s, extended measurement range: compressed air >100 ... 150 m/s, in accordance with ISO 8778, Flow display range: 0 ... 4890 l/min

Technical information

The pressure dew point must be at least 15 °C under ambient and medium temperature and may not exceed 3 °C .
 The protection class is only ensured when the plug is mounted properly. For detailed information, see operating instructions.
 The device is designed to be installed in AS series air preparation units or to be fitted as a stand-alone device using a W05 block assembly kit.
 Liquid oil or water must be separated via prefiltering. If it is not separated sufficiently, drifting may result.
 Precision- Standard measurement range: ±3% of measured value, + 0.3% of final value- Extended measurement range: ±8% of measured value, + 1% of final value

Technical information

Material	
Housing	Polyamide, Polycarbonate
Seals	Fluorocaoutchouc

Dimensions

Dimensions in mm

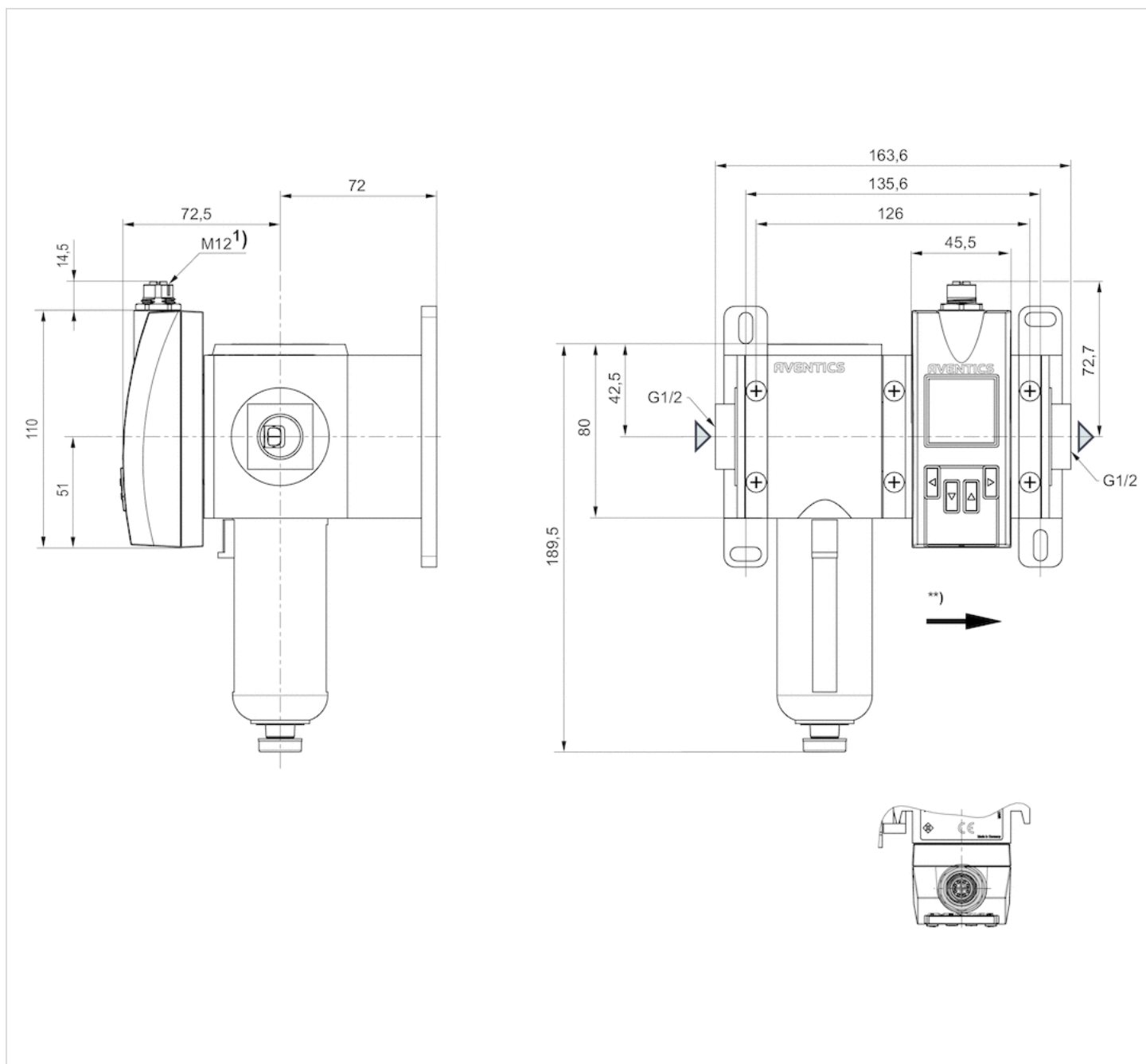

* Internal thread

** Flow direction

Pin assignments

Pin assignments, M12, X-coded

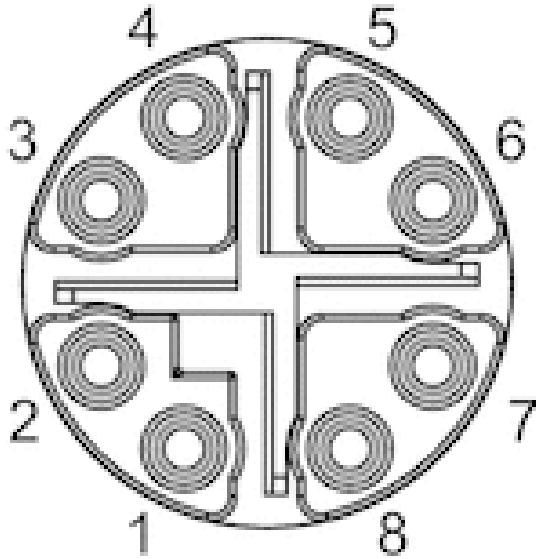

Pin	1	2	3	4	7	8	5
Color	WH / OG	OG	WH / GN	GN	WH / BU	BU	WH / BN
Function	TX(+) + POE	TX(-) + POE	RX(+) - POE	RX(-) - POE	POE+	POE+	POE-
			6				
			BN				
			POE-				

Flow sensor, Ethernet, Series AF2

- Ethernet, With mounting
- Flow measuring principle: calorimetric
- Qn min. 22 l/min
- Qn max. 6490 l/min
- Electrical connection Plug, M12x1, 8-pin

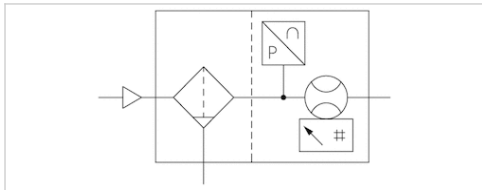

Certificates	CE declaration of conformity, RoHS
Working pressure min./max.	0 ... 16 bar
Ambient temperature min./max.	-20 ... 60 °C
Medium temperature min./max.	-20 ... 60 °C
Medium	Compressed air, Argon, Nitrogen, Helium, Carbon dioxide
filter porosity	5 µm
Display	OLED
Flow display unit	l/sec, l/min, m³/min, m³/h, ft³/s, m³/min
Pressure display unit	bar, psi
Temperature display unit	°C, °F
DC operating voltage min.	36 V DC
DC operating voltage max.	57 V DC
Power consumption max.	5 W
Response time	10 ms
Protection class	IP65, IP67 according to IEC 60529
Shock resistance max.	30 g, 11 ms
Vibration resistance	1 g (10 - 2000 Hz) IEC 60068 - 2-6
Reproducibility	± 1.5% of the measured value
Weight	2,82 kg
*)	The delivered product may vary from that in the illustration.

Technical data

Part No.	for series	Compressed air connection	Nominal flow Qn	
			Min., standard	Max., standard
R412026839	AS5	G 1	22 l/min	4326 l/min
			Nominal flow Qn	
			Max., extended	
R412026839			6490 l/min	

Standard measurement range for flow measurement: compressed air 0.5 ... 100 m/s, extended measurement range: compressed air >100 ... 150 m/s, in accordance with ISO 8778, Flow display range: 0 ... 12980 l/min

Technical information

The pressure dew point must be at least 15 °C under ambient and medium temperature and may not exceed 3 °C .
The protection class is only ensured when the plug is mounted properly. For detailed information, see operating instructions.
The device is designed to be installed in AS series air preparation units or to be fitted as a stand-alone device using a W05 block assembly kit.
Liquid oil or water must be separated via prefiltering. If it is not separated sufficiently, drifting may result.
Precision- Standard measurement range: $\pm 3\%$ of measured value, + 0.3% of final value- Extended measurement range: $\pm 8\%$ of measured value, + 1% of final value

Technical information

Material	
Housing	Polyamide, Polycarbonate
Seals	Fluorocaoutchouc

Dimensions

Dimensions in mm

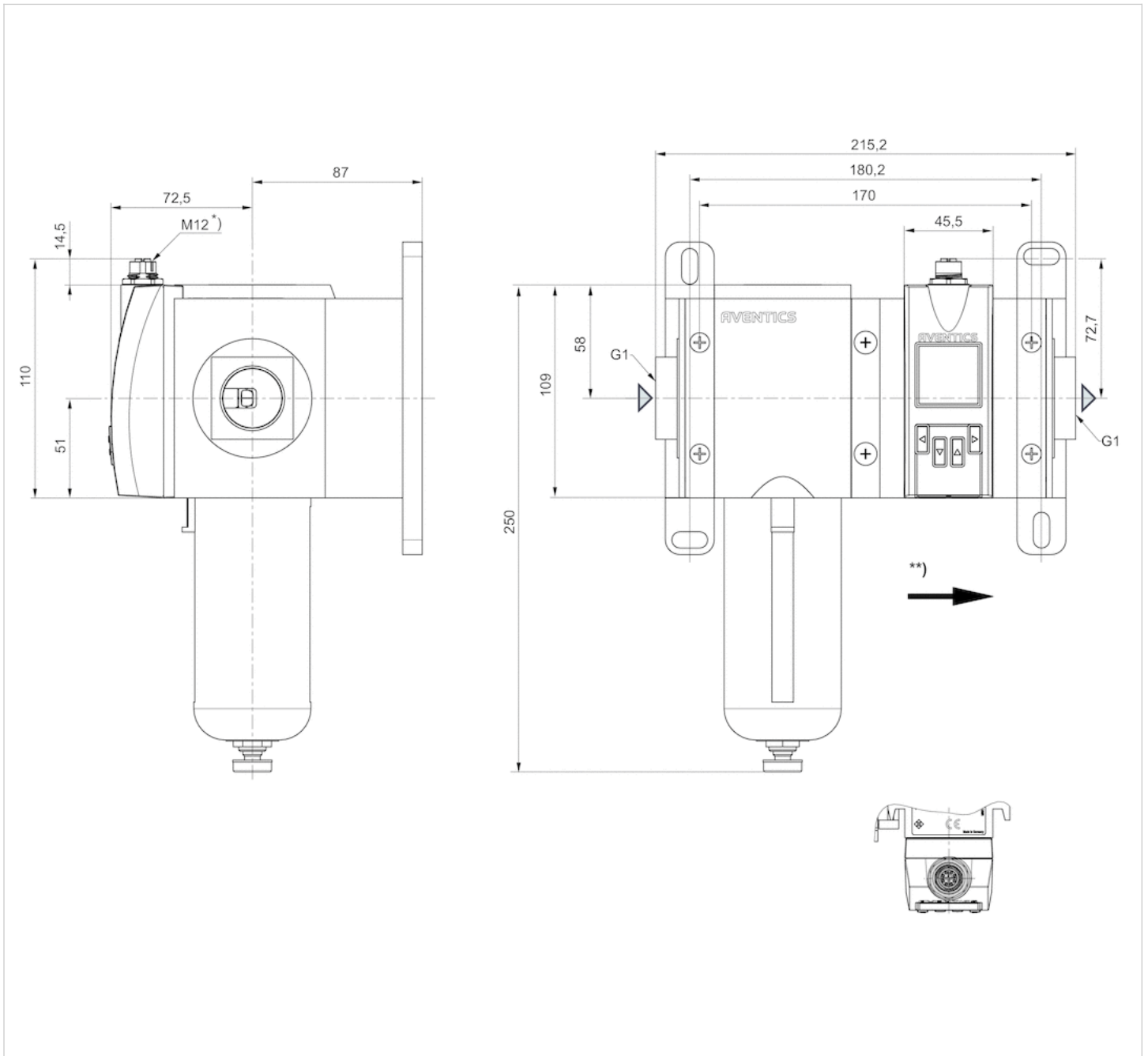

* Internal thread

** Flow direction

Pin assignments

Pin assignments, M12, X-coded

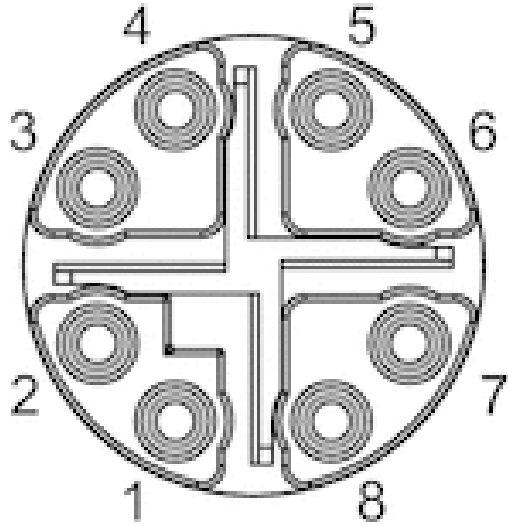

Pin	1	2	3	4	7	8	5
Color	WH / OG	OG	WH / GN	GN	WH / BU	BU	WH / BN
Function	TX(+) + POE	TX(-) + POE	RX(+) - POE	RX(-) - POE	POE+	POE+	POE-
			6				
			BN				
			POE-				

Flow sensor, IO-Link, Series AF2

- 2 analog outputs, 2 switch outputs, 1 frequency output, 1 pulse output, IO-Link, Without mounting
- Flow measuring principle: calorimetric
- Qn min. 5 l/min
- Qn max. 1590 l/min
- Electrical connection Plug, M12x1, 5-pin

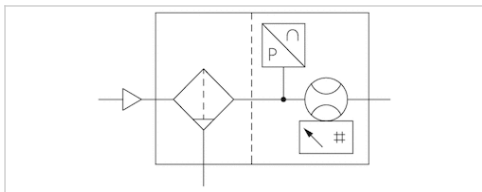

Certificates	CE declaration of conformity, RoHS
Working pressure min./max.	0 ... 16 bar
Ambient temperature min./max.	-20 ... 60 °C
Medium temperature min./max.	-20 ... 60 °C
Medium	Compressed air, Argon, Nitrogen, Helium, Carbon dioxide
filter porosity	5 µm
Display	OLED
Flow display unit	l/sec, l/min, m³/min, m³/h, ft³/s, m³/min
Pressure display unit	bar, psi
Temperature display unit	°C, °F
DC operating voltage min.	17 V DC
DC operating voltage max.	30 V DC
Max. power consumption *)	175 mA
Response time	10 ms
Protection class	IP65, IP67 according to IEC 60529
Short circuit resistance	short circuit resistant
Shock resistance max.	30 g, 11 ms
Vibration resistance	1 g (10 - 2000 Hz) IEC 60068 - 2-6
Reproducibility	± 1.5% of the measured value
Weight	0,85 kg
*)	Current consumption without load The delivered product may vary from that in the illustration.

Technical data

Part No.	for series	Compressed air connection	Nominal flow Qn	
			Min., standard	Max., standard
R412027176	AS2	G 3/8	5 l/min	1060 l/min

Part No.	Nominal flow Qn
	Max., extended
R412027176	1590 l/min

Standard measurement range for flow measurement: compressed air 0.5 ... 100 m/s, extended measurement range: compressed air >100 ... 150 m/s, in accordance with ISO 8778, Flow display range: 0 ... 3180 l/min

Technical information

The pressure dew point must be at least 15 °C under ambient and medium temperature and may not exceed 3 °C .
 The protection class is only ensured when the plug is mounted properly. For detailed information, see operating instructions.
 The device is designed to be installed in AS series air preparation units or to be fitted as a stand-alone device using a W05 block assembly kit.
 Liquid oil or water must be separated via prefiltering. If it is not separated sufficiently, drifting may result.
 Precision- Standard measurement range: ±3% of measured value, + 0.3% of final value- Extended measurement range: ±8% of measured value, + 1% of final value
 The IO-Link device description (IODD) for the AF2 flow rate sensor is available for download in the Media Center.

Technical information

Material	
Housing	Polyamide, Polycarbonate
Seals	Fluorocautchouc

Dimensions

Dimensions in mm

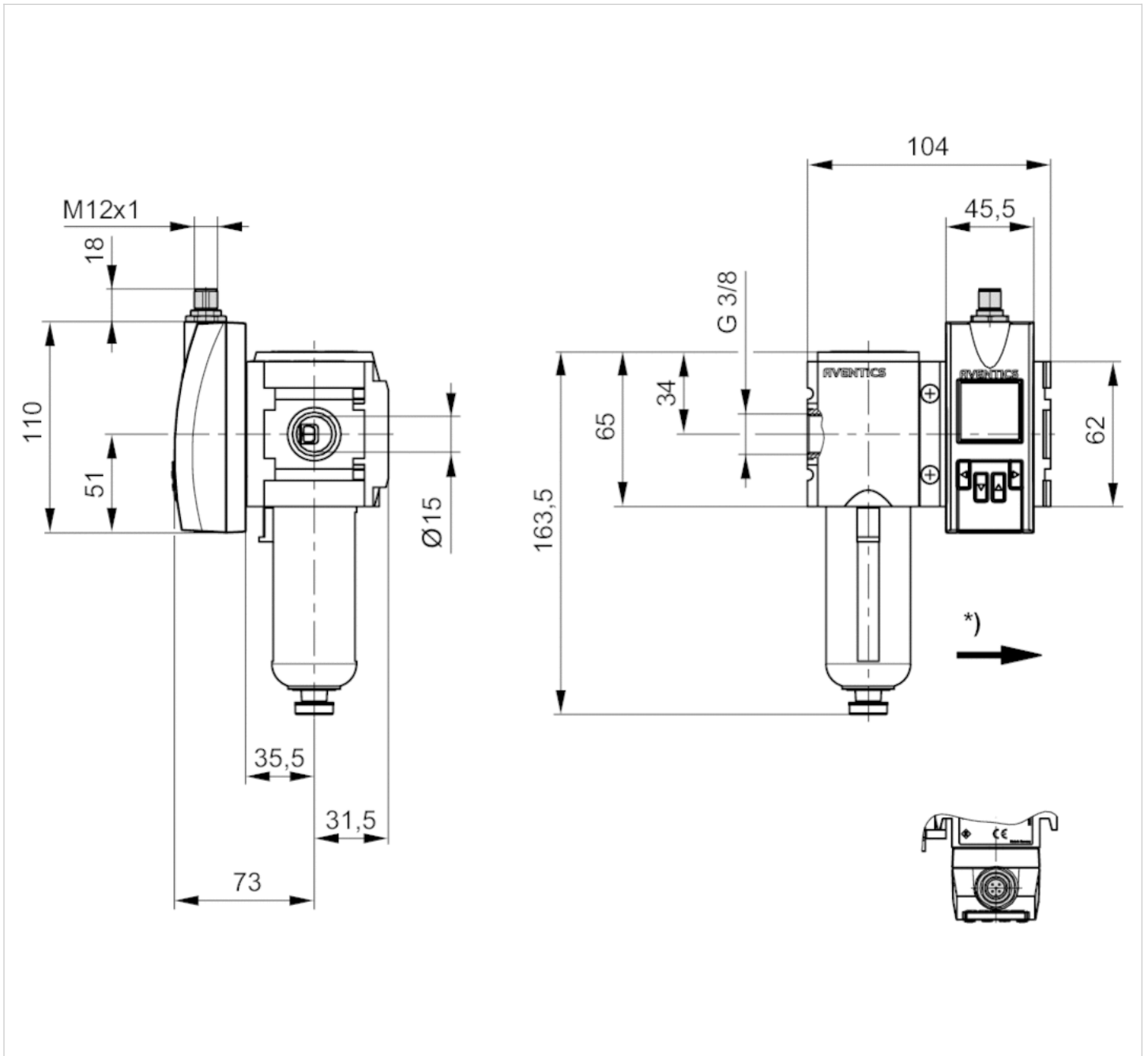

* Flow direction

Pin assignments

Pin assignments, M12x1, 5-pin

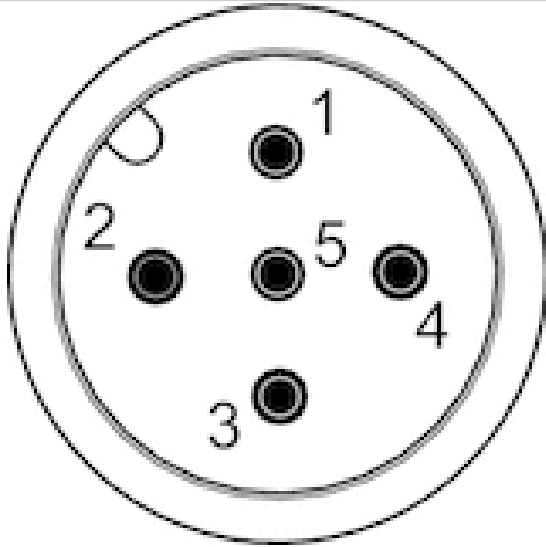

Pin	1	2	3
Allocation	L+	QA (output 4 ... 20 mA)	m = mass
	4	5	
	C/Q1 (IO-Link/switch output)	Analog output 4 ... 20 mA	

Flow sensor, IO-Link, Series AF2

- 2 analog outputs, 2 switch outputs, 1 frequency output, 1 pulse output, IO-Link, Without mounting
- Flow measuring principle: calorimetric
- Qn min. 8 l/min
- Qn max. 2445 l/min
- Electrical connection Plug, M12x1, 5-pin

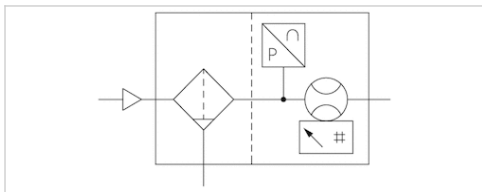

Certificates	CE declaration of conformity, RoHS
Working pressure min./max.	0 ... 16 bar
Ambient temperature min./max.	-20 ... 60 °C
Medium temperature min./max.	-20 ... 60 °C
Medium	Compressed air, Argon, Nitrogen, Helium, Carbon dioxide
filter porosity	5 µm
Display	OLED
Flow display unit	l/sec, l/min, m³/min, m³/h, ft³/s, m³/min
Pressure display unit	bar, psi
Temperature display unit	°C, °F
DC operating voltage min.	17 V DC
DC operating voltage max.	30 V DC
Max. power consumption *)	175 mA
Response time	10 ms
Protection class	IP65, IP67 according to IEC 60529
Short circuit resistance	short circuit resistant
Shock resistance max.	30 g, 11 ms
Vibration resistance	1 g (10 - 2000 Hz) IEC 60068 - 2-6
Reproducibility	± 1.5% of the measured value
Weight	1,25 kg
*)	Current consumption without load

Technical data

Part No.	for series	Compressed air connection	Nominal flow Qn	
			Min., standard	Max., standard
R412027177	AS3	G 1/2	8 l/min	1630 l/min

Part No.	Nominal flow Qn
	Max., extended
R412027177	2445 l/min

Standard measurement range for flow measurement: compressed air 0.5 ... 100 m/s, extended measurement range: compressed air >100 ... 150 m/s, in accordance with ISO 8778, Flow display range: 0 ... 4890 l/min

Technical information

The pressure dew point must be at least 15 °C under ambient and medium temperature and may not exceed 3 °C .
 The protection class is only ensured when the plug is mounted properly. For detailed information, see operating instructions.
 The device is designed to be installed in AS series air preparation units or to be fitted as a stand-alone device using a W05 block assembly kit.
 Liquid oil or water must be separated via prefiltering. If it is not separated sufficiently, drifting may result.
 Precision- Standard measurement range: ±3% of measured value, + 0.3% of final value- Extended measurement range: ±8% of measured value, + 1% of final value
 The IO-Link device description (IODD) for the AF2 flow rate sensor is available for download in the Media Center.

Technical information

Material	
Housing	Polyamide, Polycarbonate
Seals	Fluorocaoutchouc

Dimensions

Dimensions in mm

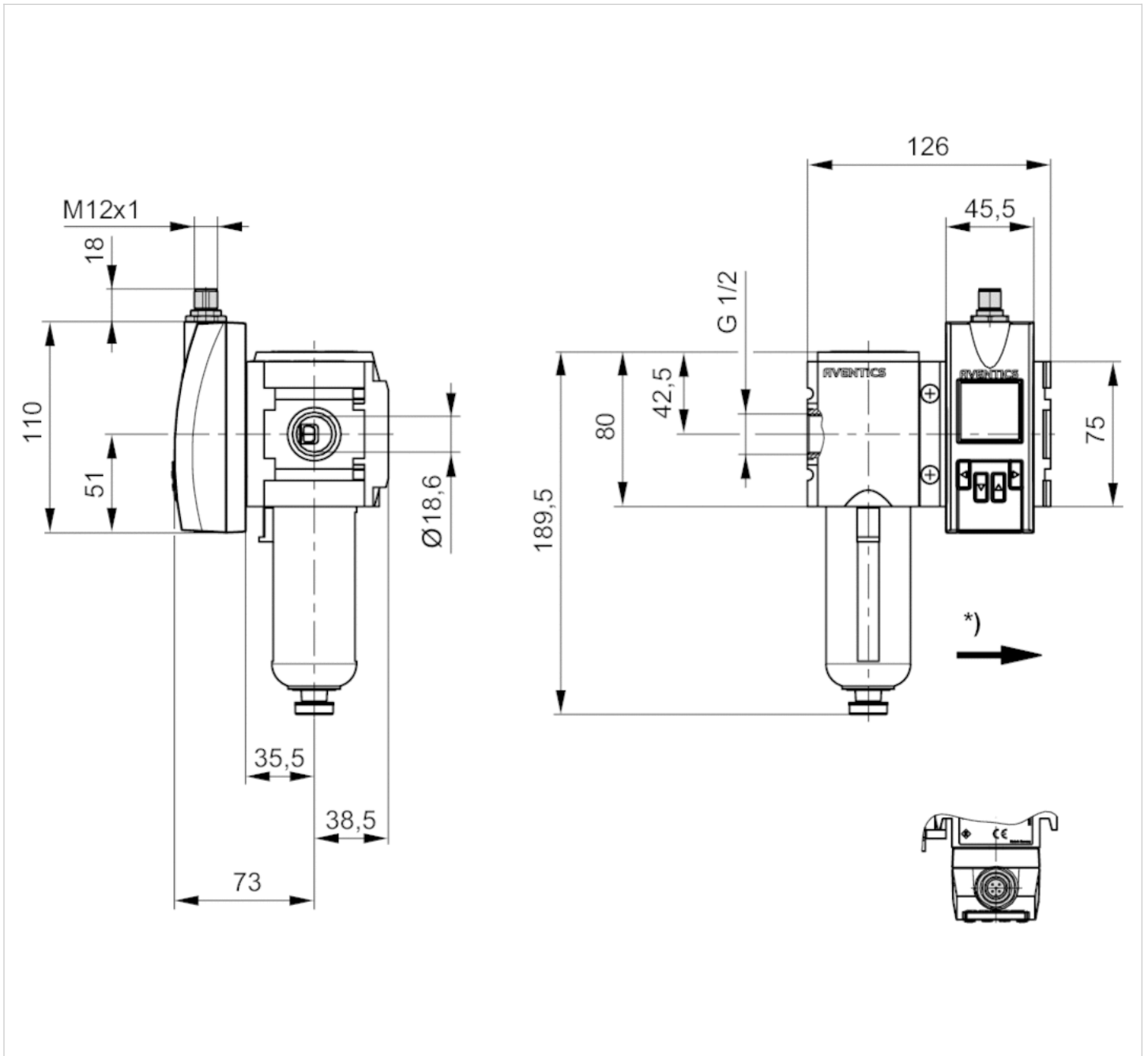

* Flow direction

Pin assignments

Pin assignments, M12x1, 5-pin

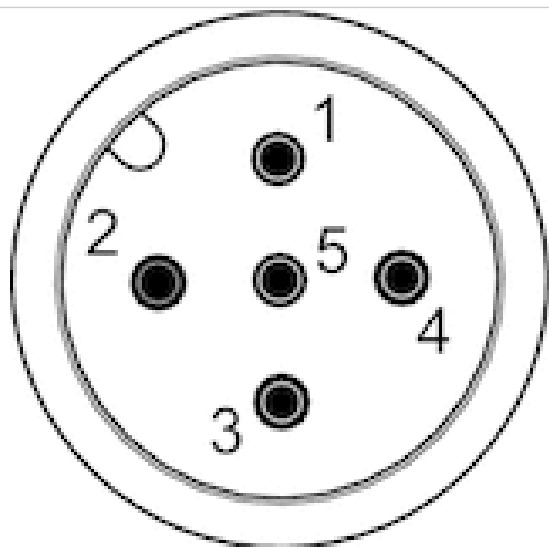

Pin	1	2	3
Allocation	L+	QA (output 4 ... 20 mA)	m = mass
	4	5	
	C/Q1 (IO-Link/switch output)	Analog output 4 ... 20 mA	

Flow sensor, IO-Link, Series AF2

- 2 analog outputs, 2 switch outputs, 1 frequency output, 1 pulse output, IO-Link, Without mounting
- Flow measuring principle: calorimetric
- Qn min. 22 l/min
- Qn max. 6490 l/min
- Electrical connection Plug, M12x1, 5-pin

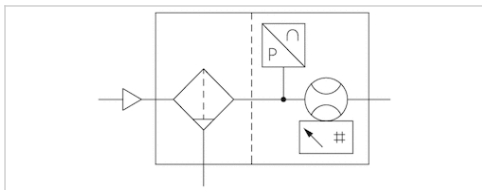

Certificates	CE declaration of conformity, RoHS
Working pressure min./max.	0 ... 16 bar
Ambient temperature min./max.	-20 ... 60 °C
Medium temperature min./max.	-20 ... 60 °C
Medium	Compressed air, Argon, Nitrogen, Helium, Carbon dioxide
filter porosity	5 µm
Display	OLED
Flow display unit	l/sec, l/min, m³/min, m³/h, ft³/s, m³/min
Pressure display unit	bar, psi
Temperature display unit	°C, °F
DC operating voltage min.	17 V DC
DC operating voltage max.	30 V DC
Max. power consumption *)	175 mA
Response time	10 ms
Protection class	IP65, IP67 according to IEC 60529
Short circuit resistance	short circuit resistant
Shock resistance max.	30 g, 11 ms
Vibration resistance	1 g (10 - 2000 Hz) IEC 60068 - 2-6
Reproducibility	± 1.5% of the measured value
Weight	2,3 kg
*)	Current consumption without load The delivered product may vary from that in the illustration.

Technical data

Part No.	for series	Compressed air connection	Nominal flow Qn	
			Min., standard	Max., standard
R412027178	AS5	G 1	22 l/min	4326 l/min

Part No.	Nominal flow Qn
	Max., extended
R412027178	6490 l/min

Standard measurement range for flow measurement: compressed air 0.5 ... 100 m/s, extended measurement range: compressed air >100 ... 150 m/s, in accordance with ISO 8778, Flow display range: 0 ... 12980 l/min

Technical information

The pressure dew point must be at least 15 °C under ambient and medium temperature and may not exceed 3 °C .
 The protection class is only ensured when the plug is mounted properly. For detailed information, see operating instructions.
 The device is designed to be installed in AS series air preparation units or to be fitted as a stand-alone device using a W05 block assembly kit.
 Liquid oil or water must be separated via prefiltering. If it is not separated sufficiently, drifting may result.
 Precision- Standard measurement range: ±3% of measured value, + 0.3% of final value- Extended measurement range: ±8% of measured value, + 1% of final value
 The IO-Link device description (IODD) for the AF2 flow rate sensor is available for download in the Media Center.

Technical information

Material	
Housing	Polyamide, Polycarbonate
Seals	Fluorocautchouc

Dimensions

Dimensions in mm

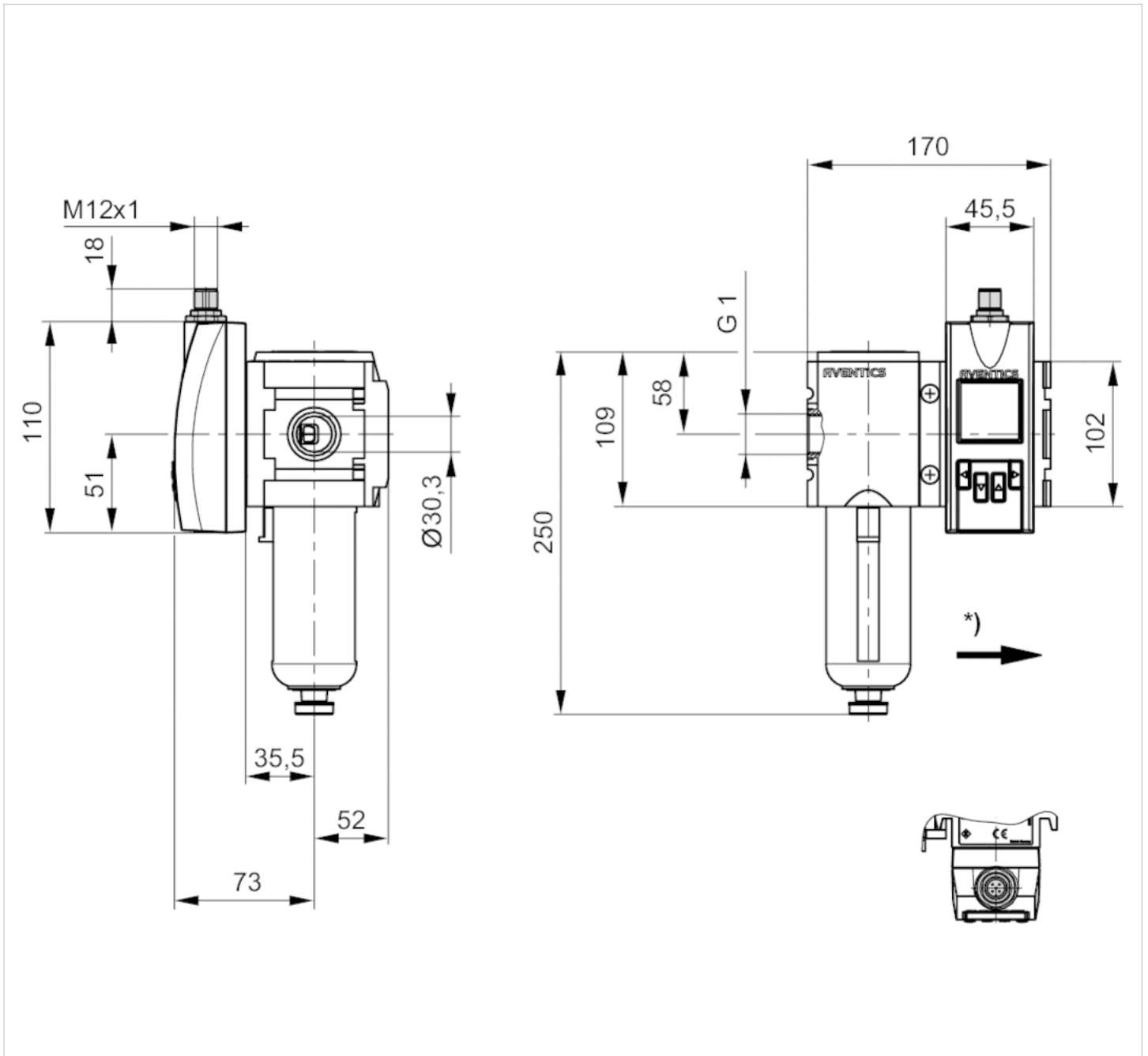

* Flow direction

Pin assignments

Pin assignments, M12x1, 5-pin

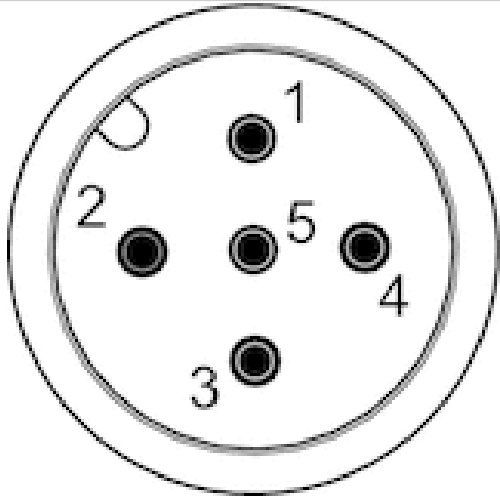

Pin	1	2	3
Allocation	L+	QA (output 4 ... 20 mA)	m = mass
	4	5	
	C/Q1 (IO-Link/switch output)	Analog output 4 ... 20 mA	

Flow sensor, Ethernet, Series AF2

- Ethernet, Without mounting
- Flow measuring principle: calorimetric
- Qn min. 5 l/min
- Qn max. 1590 l/min
- Electrical connection Plug, M12x1, 8-pin

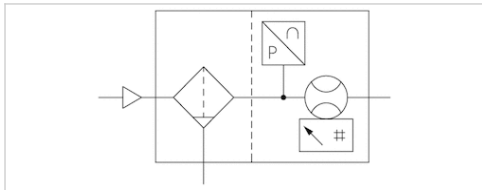

Certificates	CE declaration of conformity, RoHS
Working pressure min./max.	0 ... 16 bar
Ambient temperature min./max.	-20 ... 60 °C
Medium temperature min./max.	-20 ... 60 °C
Medium	Compressed air, Argon, Nitrogen, Helium, Carbon dioxide
filter porosity	5 µm
Display	OLED
Flow display unit	l/sec, l/min, m³/min, m³/h, ft³/s, m³/min
Pressure display unit	bar, psi
Temperature display unit	°C, °F
DC operating voltage min.	36 V DC
DC operating voltage max.	57 V DC
Power consumption max.	5 W
Response time	10 ms
Protection class	IP65, IP67 according to IEC 60529
Shock resistance max.	30 g, 11 ms
Vibration resistance	1 g (10 - 2000 Hz) IEC 60068 - 2-6
Reproducibility	± 1.5% of the measured value
Weight	0,85 kg
*)	The delivered product may vary from that in the illustration.

Technical data

Part No.	for series	Compressed air connection	Nominal flow Qn	
			Min., standard	Max., standard
R412027179	AS2	G 3/8	5 l/min	1060 l/min
			Nominal flow Qn	
			Max., extended	
R412027179			1590 l/min	

Standard measurement range for flow measurement: compressed air 0.5 ... 100 m/s, extended measurement range: compressed air >100 ... 150 m/s, in accordance with ISO 8778, Flow display range: 0 ... 3180 l/min

Technical information

The pressure dew point must be at least 15 °C under ambient and medium temperature and may not exceed 3 °C .

The protection class is only ensured when the plug is mounted properly. For detailed information, see operating instructions.

The device is designed to be installed in AS series air preparation units or to be fitted as a stand-alone device using a W05 block assembly kit.

Liquid oil or water must be separated via prefiltering. If it is not separated sufficiently, drifting may result.

Precision- Standard measurement range: $\pm 3\%$ of measured value, + 0.3% of final value- Extended measurement range: $\pm 8\%$ of measured value, + 1% of final value

Technical information

Material	
Housing	Polyamide, Polycarbonate
Seals	Fluorocaoutchouc

Dimensions

Dimensions in mm

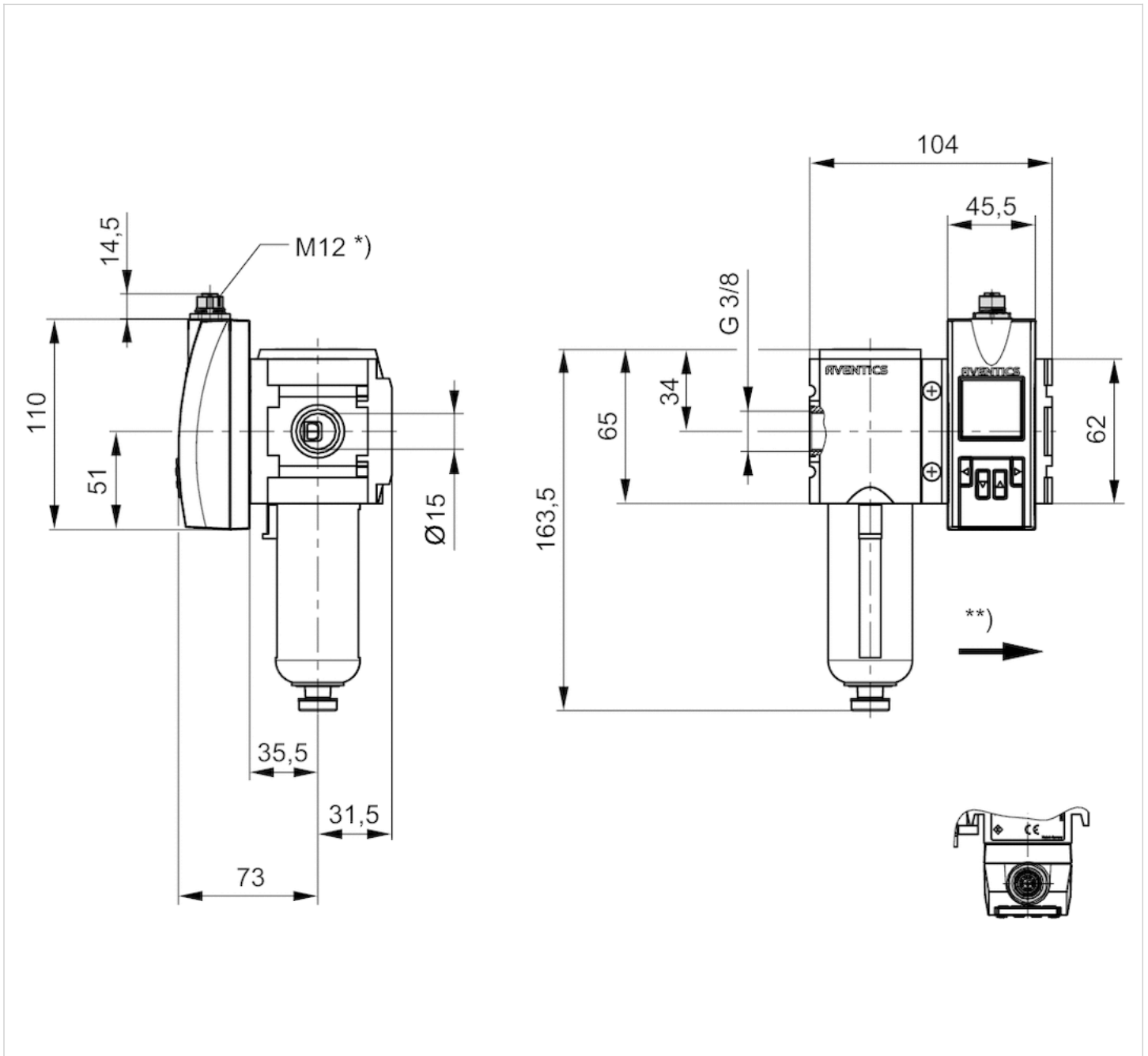

* Internal thread

** Flow direction

Pin assignments

Pin assignments, M12, X-coded

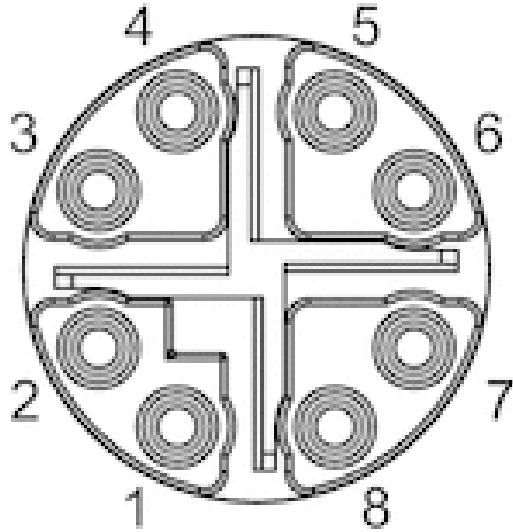

Pin	1	2	3	4	7	8	5
Color	WH / OG	OG	WH / GN	GN	WH / BU	BU	WH / BN
Function	TX(+) + POE	TX(-) + POE	RX(+) - POE	RX(-) - POE	POE+	POE+	POE-
			6				
			BN				
			POE-				

Flow sensor, Ethernet, Series AF2

- Ethernet, Without mounting
- Flow measuring principle: calorimetric
- Qn min. 8 l/min
- Qn max. 2445 l/min
- Electrical connection Plug, M12x1, 8-pin

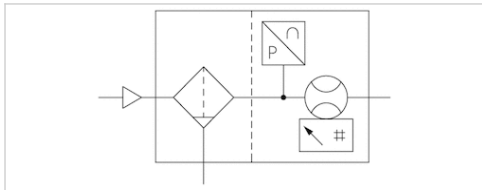

Certificates	CE declaration of conformity, RoHS
Working pressure min./max.	0 ... 16 bar
Ambient temperature min./max.	-20 ... 60 °C
Medium temperature min./max.	-20 ... 60 °C
Medium	Compressed air, Argon, Nitrogen, Helium, Carbon dioxide
filter porosity	5 µm
Display	OLED
Flow display unit	l/sec, l/min, m³/min, m³/h, ft³/s, m³/min
Pressure display unit	bar, psi
Temperature display unit	°C, °F
DC operating voltage min.	36 V DC
DC operating voltage max.	57 V DC
Power consumption max.	5 W
Response time	10 ms
Protection class	IP65, IP67 according to IEC 60529
Shock resistance max.	30 g, 11 ms
Vibration resistance	1 g (10 - 2000 Hz) IEC 60068 - 2-6
Reproducibility	± 1.5% of the measured value
Weight	1,25 kg

Technical data

Part No.	for series	Compressed air connection	Nominal flow Qn	
			Min., standard	Max., standard
R412027180	AS3	G 1/2	8 l/min	1630 l/min

Part No.	Nominal flow Qn
	Max., extended
R412027180	2445 l/min

Standard measurement range for flow measurement: compressed air 0.5 ... 100 m/s, extended measurement range: compressed air >100 ... 150 m/s, in accordance with ISO 8778, Flow display range: 0 ... 4890 l/min

Technical information

The pressure dew point must be at least 15 °C under ambient and medium temperature and may not exceed 3 °C .
 The protection class is only ensured when the plug is mounted properly. For detailed information, see operating instructions.
 The device is designed to be installed in AS series air preparation units or to be fitted as a stand-alone device using a W05 block assembly kit.
 Liquid oil or water must be separated via prefiltering. If it is not separated sufficiently, drifting may result.
 Precision- Standard measurement range: ±3% of measured value, + 0.3% of final value- Extended measurement range: ±8% of measured value, + 1% of final value

Technical information

Material	
Housing	Polyamide, Polycarbonate
Seals	Fluorocaoutchouc

Dimensions

Dimensions in mm

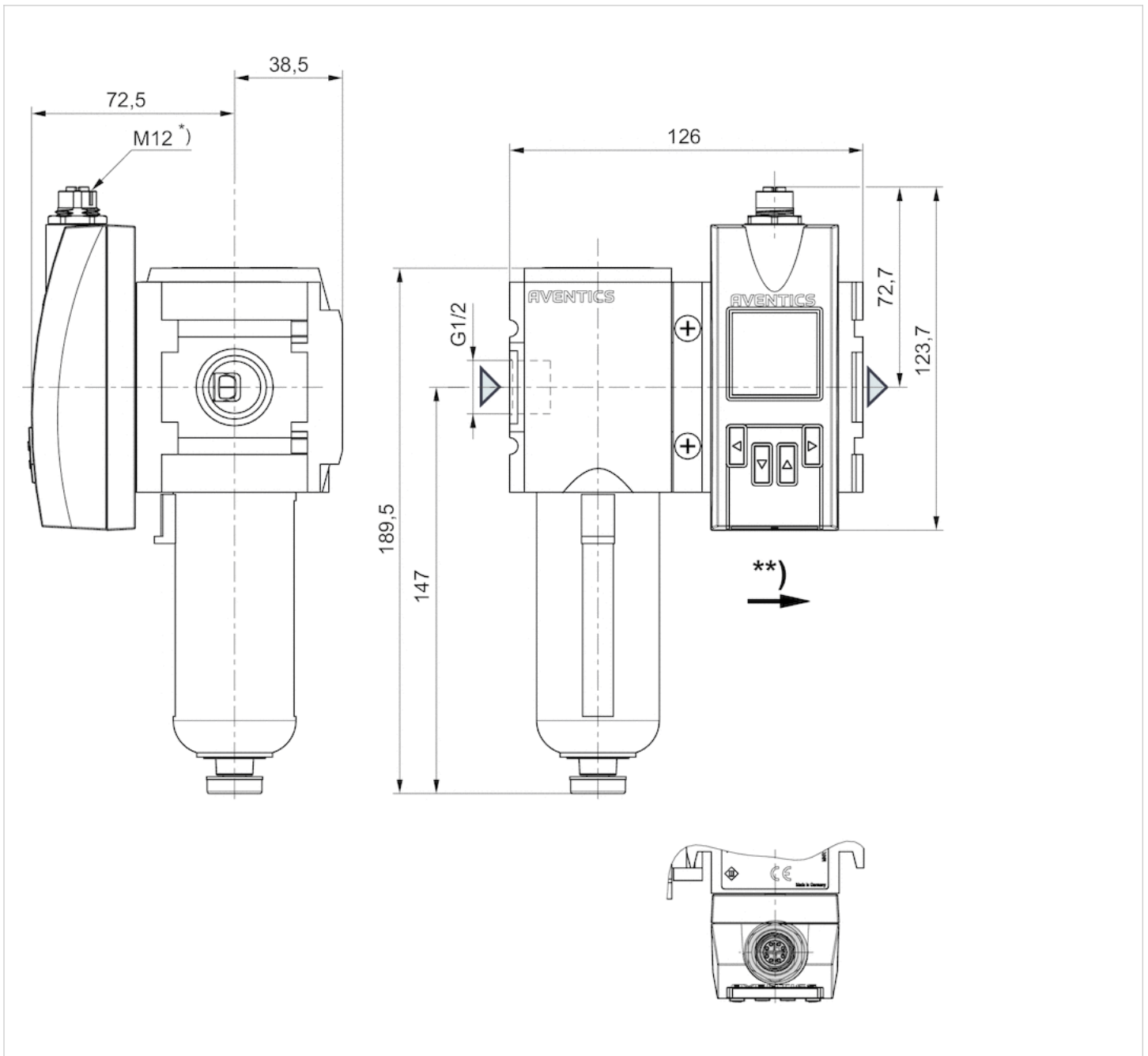

* Internal thread

** Flow direction

Pin assignments

Pin assignments, M12, X-coded

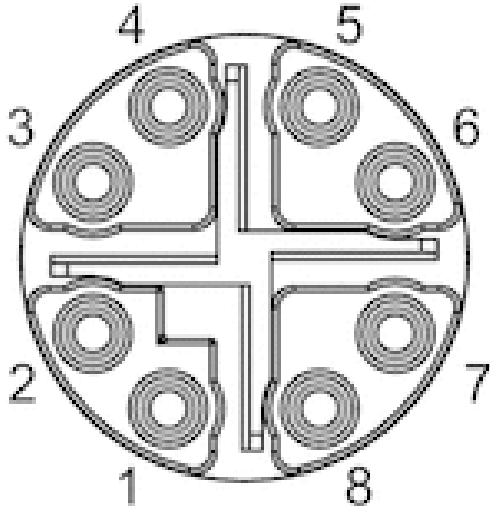

Pin	1	2	3	4	7	8	5
Color	WH / OG	OG	WH / GN	GN	WH / BU	BU	WH / BN
Function	TX(+) + POE	TX(-) + POE	RX(+) - POE	RX(-) - POE	POE+	POE+	POE-
			6				
			BN				
			POE-				

Flow sensor, Ethernet, Series AF2

- Ethernet, Without mounting
- Flow measuring principle: calorimetric
- Qn min. 22 l/min
- Qn max. 6490 l/min
- Electrical connection Plug, M12x1, 8-pin

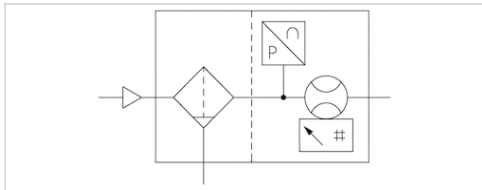

Certificates	CE declaration of conformity, RoHS
Working pressure min./max.	0 ... 16 bar
Ambient temperature min./max.	-20 ... 60 °C
Medium temperature min./max.	-20 ... 60 °C
Medium	Compressed air, Argon, Nitrogen, Helium, Carbon dioxide
filter porosity	5 µm
Display	OLED
Flow display unit	l/sec, l/min, m³/min, m³/h, ft³/s, m³/min
Pressure display unit	bar, psi
Temperature display unit	°C, °F
DC operating voltage min.	36 V DC
DC operating voltage max.	57 V DC
Power consumption max.	5 W
Response time	10 ms
Protection class	IP65, IP67 according to IEC 60529
Shock resistance max.	30 g, 11 ms
Vibration resistance	1 g (10 - 2000 Hz) IEC 60068 - 2-6
Reproducibility	± 1.5% of the measured value
Weight	2,3 kg
*)	The delivered product may vary from that in the illustration.

Technical data

Part No.	for series	Compressed air connection	Nominal flow Qn	
			Min., standard	Max., standard
R412027181	AS5	G 1	22 l/min	4326 l/min
			Nominal flow Qn	
			Max., extended	
R412027181			6490 l/min	

Standard measurement range for flow measurement: compressed air 0.5 ... 100 m/s, extended measurement range: compressed air >100 ... 150 m/s, in accordance with ISO 8778, Flow display range: 0 ... 12980 l/min

Technical information

The pressure dew point must be at least 15 °C under ambient and medium temperature and may not exceed 3 °C .

The protection class is only ensured when the plug is mounted properly. For detailed information, see operating instructions.

The device is designed to be installed in AS series air preparation units or to be fitted as a stand-alone device using a W05 block assembly kit.

Liquid oil or water must be separated via prefiltering. If it is not separated sufficiently, drifting may result.

Precision- Standard measurement range: $\pm 3\%$ of measured value, + 0.3% of final value- Extended measurement range: $\pm 8\%$ of measured value, + 1% of final value

Technical information

Material	
Housing	Polyamide, Polycarbonate
Seals	Fluorocaoutchouc

Dimensions

Dimensions in mm

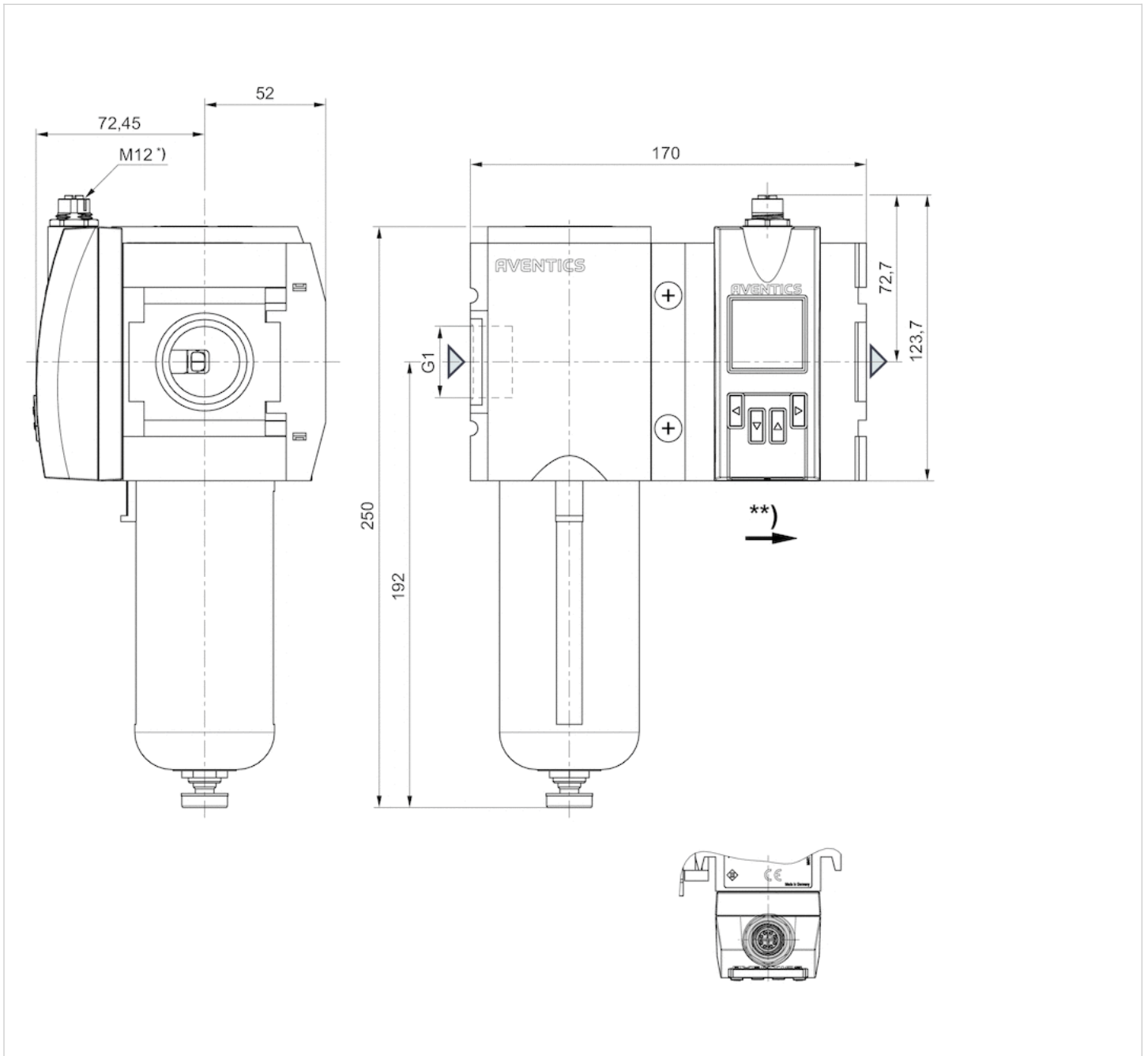

* Internal thread

** Flow direction

Pin assignments

Pin assignments, M12, X-coded

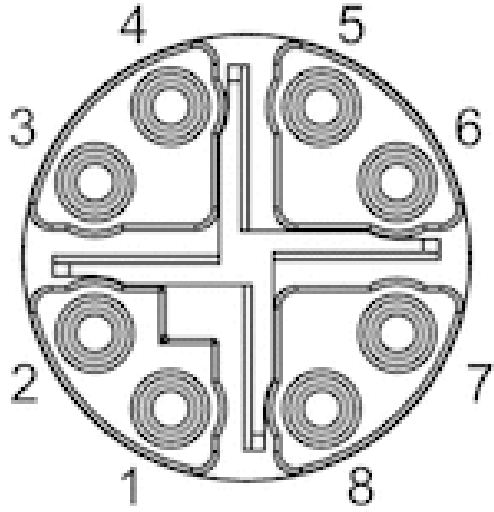

Pin	1	2	3	4	7	8	5
Color	WH / OG	OG	WH / GN	GN	WH / BU	BU	WH / BN
Function	TX(+) + POE	TX(-) + POE	RX(+) - POE	RX(-) - POE	POE+	POE+	POE-
			6				
			BN				
			POE-				

Series AF2 flow sensor, 652 filter version, Ethernet

G652AVBP4JA001N

Series 652

- The pressure dew point must be at least 15 °C under ambient and medium temperature and may not exceed 3 °C. The protection class is only ensured when the plug is mounted properly. For detailed information, see operating instructions. Precision: Standard measurement range: $\pm 4\%$ of measured value, + 0.5% of final value. Extended measurement range: $\pm 8\%$ of measured value, + 1% of final value.



Technical data

Industry
Industrial

Note

Integrated web server, 48 VDC connection via Power over Ethernet

Switching principle

Flow measuring principle: calorimetric

Protocol

TCP/IP
OPC UA
MQTT

Nominal flow Qn min., standard
8 l/min

Nominal flow Qn max., standard
1630 l/min

Nominal flow Qn min., extended
1630 l/min

Nominal flow Qn max., extended
2445 l/min

Compressed air connection
G 1/2

Certificates

CE declaration of conformity
RoHS

Working pressure min.
0 bar

Working pressure max
16 bar

Min. ambient temperature
-20 °C

Max. ambient temperature
50 °C

Min. medium temperature
-20 °C

Max. medium temperature
50 °C

Medium

Compressed air
Argon
Nitrogen
Helium
Carbon dioxide

filter porosity
5 μ m

Display
OLED

Flow display unit
l/sec
l/min
m³/min

m³/h
ft³/s
m³/min

Pressure display unit
bar
psi

Temperature display unit
°C
°F

Electrical connection
Plug

Electrical connection
M12x1

Electrical connection
8-pin

Power consumption max.
5 W

Operating voltage DC, min.
36 V DC

Operating voltage DC, max.
57 V DC

Response time
< 0.3 s

Shock resistance max.
30 g, 11 ms

Vibration resistance
1 g (10 - 2000 Hz) IEC 60068 - 2-6

Reproducibility
± 1.5% of the measured value

Protection class
IP65
IP67 according to IEC 60529

Weight
0.73 kg

Material

Housing material
Polyamide
Polycarbonate
Aluminum

Seal material filter
Nitrile butadiene rubber

Seal material sensor
Fluorocarbon caoutchouc

Part No.
G652AVBP4JA001N

Dimensions in inches

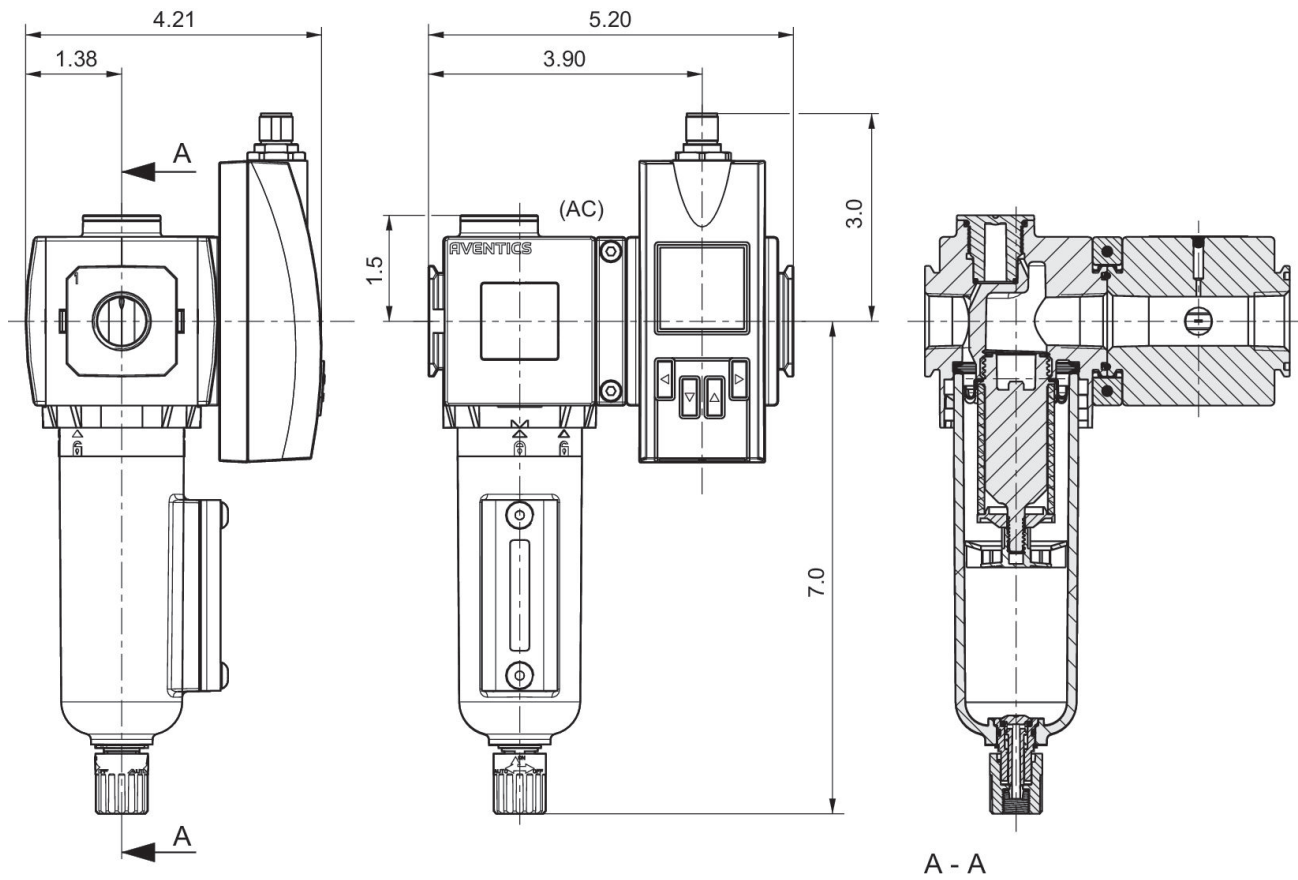

Dimensions in mm

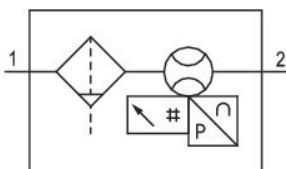
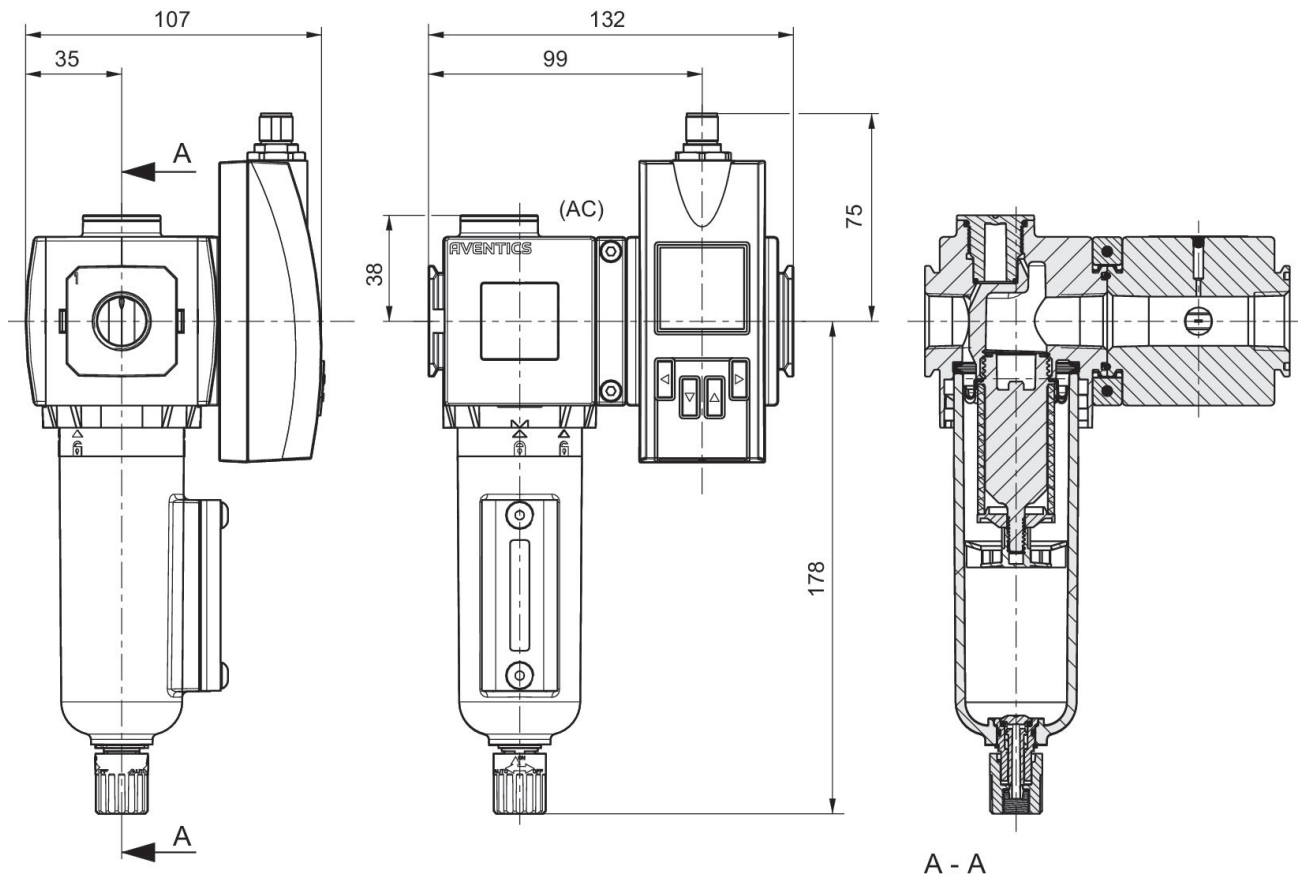

Pin assignments

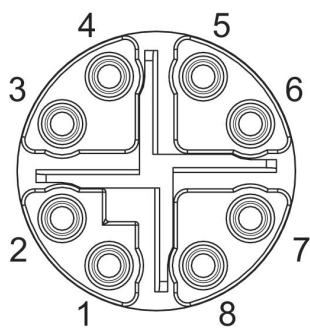

Pin	RJ45	Wire color	Identification	10/100 Mbit
1	1	WH / OG	TX(+) + POE	TxData+
2	2	OG	TX(-) + POE	TxData+

Pin	RJ45	Wire color	Identification	10/100 Mbit
3	3	WH / GN	RX(+) - POE	TxData-
4	6	GN	RX(-) - POE	TxData-
7	5	WH / BU	POE+	
8	4	BU	POE+	
5	7	WH / BN	POE-	
6	8	BN	POE-	

Series AF2 flow sensor, 652 filter version, Ethernet

8652AVBP4JA001N

Series 652

- The pressure dew point must be at least 15 °C under ambient and medium temperature and may not exceed 3 °C. The protection class is only ensured when the plug is mounted properly. For detailed information, see operating instructions. Precision: Standard measurement range: $\pm 4\%$ of measured value, + 0.5% of final value. Extended measurement range: $\pm 8\%$ of measured value, + 1% of final value.



Technical data

Industry
Industrial

Note

Integrated web server, 48 VDC connection via Power over Ethernet

Switching principle

Flow measuring principle: calorimetric

Protocol

TCP/IP
OPC UA
MQTT

Nominal flow Q_n min., standard
8 l/min

Nominal flow Q_n max., standard
1630 l/min

Nominal flow Q_n min., extended
1630 l/min

Nominal flow Q_n max., extended
2445 l/min

Compressed air connection
1/2 NPT

Certificates

CE declaration of conformity
RoHS

Working pressure min.
0 bar

Working pressure max
16 bar

Min. ambient temperature
-20 °C

Max. ambient temperature
50 °C

Min. medium temperature
-20 °C

Max. medium temperature
50 °C

Medium

Compressed air
Argon
Nitrogen
Helium
Carbon dioxide

filter porosity
5 μ m

Display
OLED

Flow display unit
l/sec
l/min
m³/min

m³/h
ft³/s
m³/min

Pressure display unit
bar
psi

Temperature display unit
°C
°F

Electrical connection
Plug

Electrical connection
M12x1

Electrical connection
8-pin

Power consumption max.
5 W

Operating voltage DC, min.
36 V DC

Operating voltage DC, max.
57 V DC

Response time
< 0.3 s

Shock resistance max.
30 g, 11 ms

Vibration resistance
1 g (10 - 2000 Hz) IEC 60068 - 2-6

Reproducibility
± 1.5% of the measured value

Protection class
IP65
IP67 according to IEC 60529

Weight
0.73 kg

Material

Housing material
Polyamide
Polycarbonate
Aluminum

Seal material filter
Nitrile butadiene rubber

Seal material sensor
Fluorocarbon caoutchouc

Part No.
8652AVBP4JA001N

Dimensions in inches

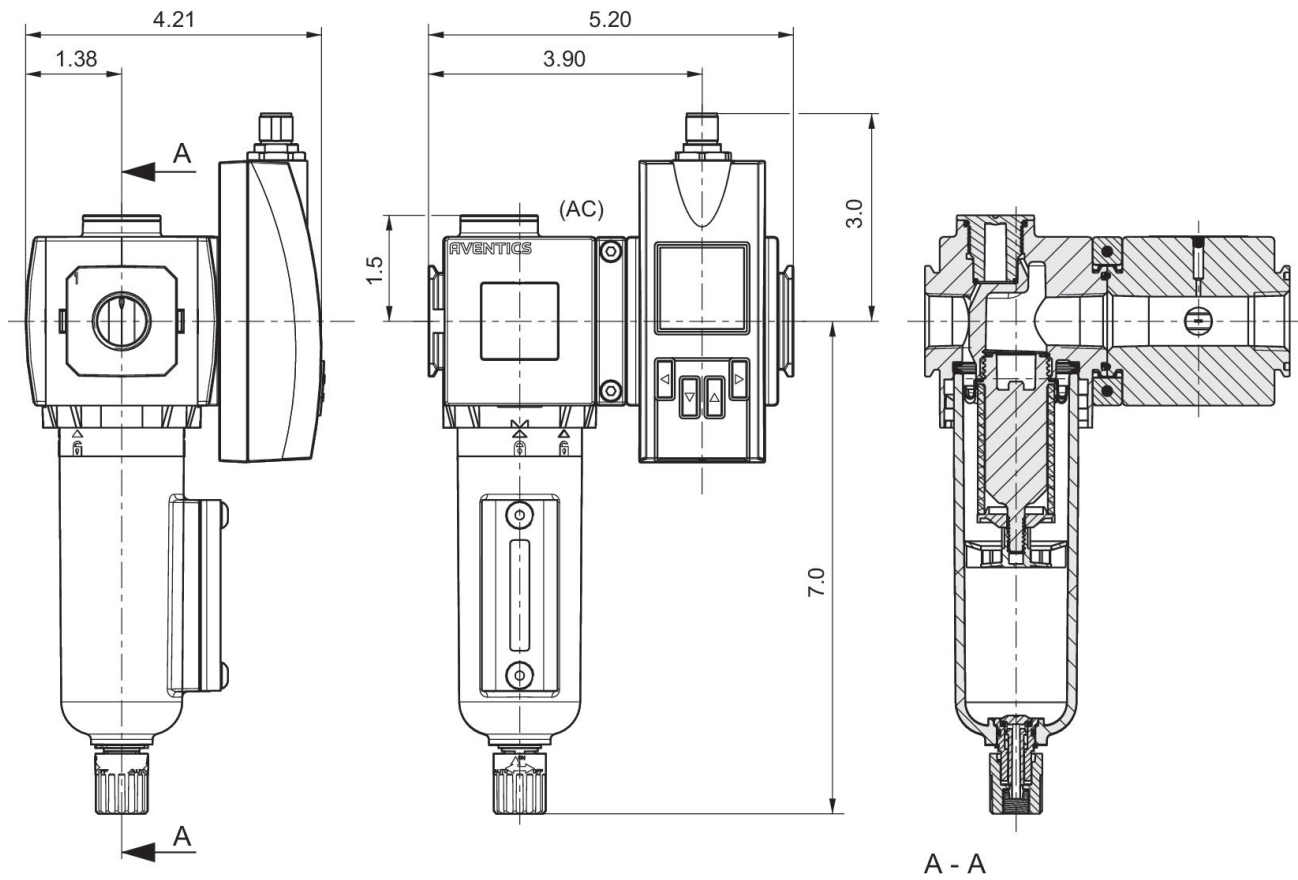

Dimensions in mm

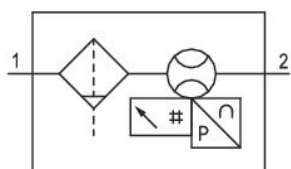
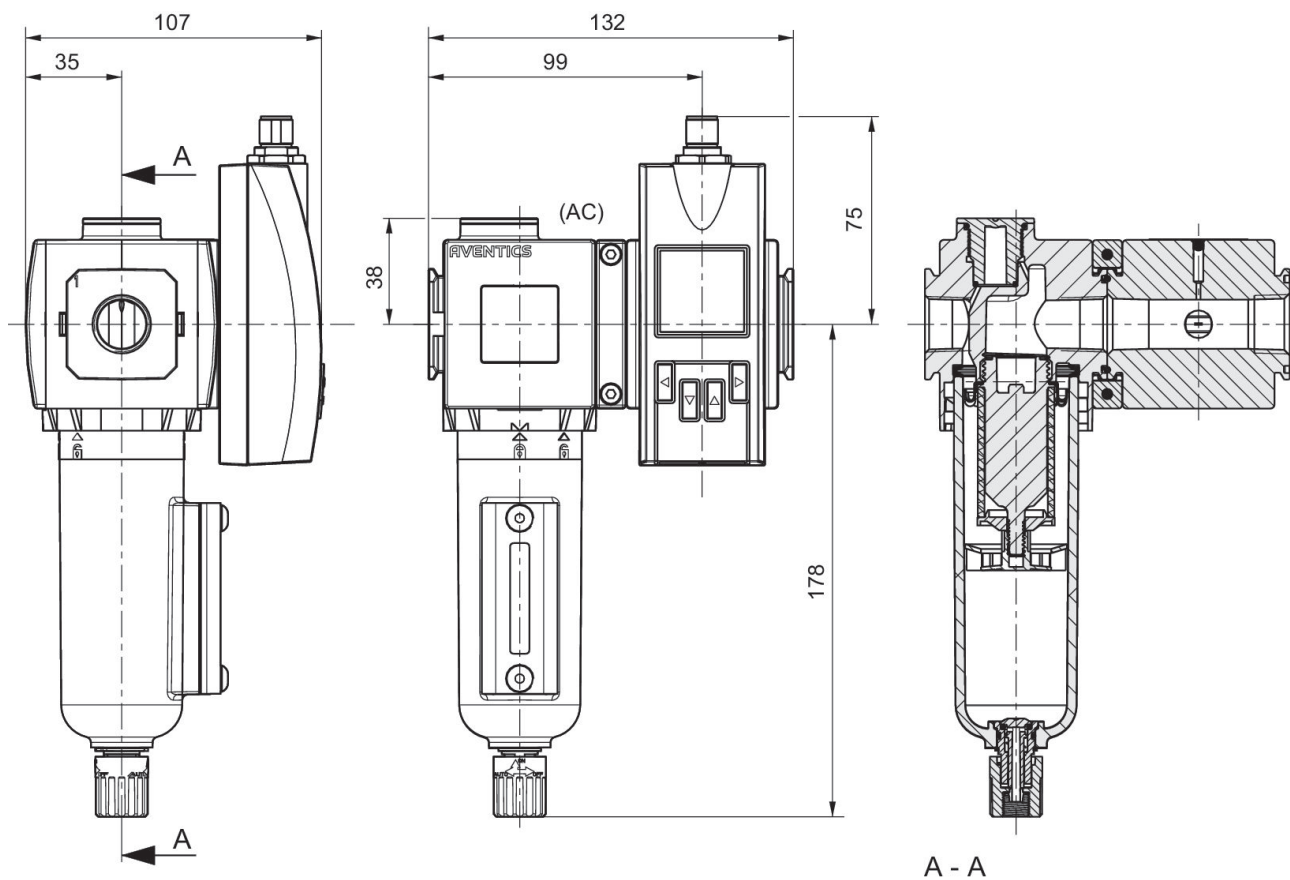

Pin assignments

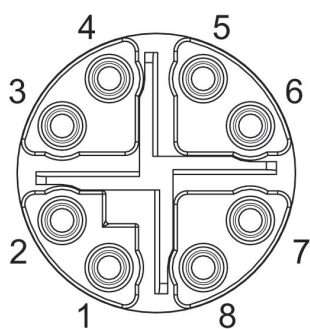

Pin	RJ45	Wire color	Identification	10/100 Mbit
1	1	WH / OG	TX(+) + POE	TxData+
2	2	OG	TX(-) + POE	TxData+

Pin	RJ45	Wire color	Identification	10/100 Mbit
3	3	WH / GN	RX(+) - POE	TxData-
4	6	GN	RX(-) - POE	TxData-
7	5	WH / BU	POE+	
8	4	BU	POE+	
5	7	WH / BN	POE-	
6	8	BN	POE-	

Series AF2 flow sensor, 652 filter version, IO-Link

G652AVBP4JA000N

Series 652

- The pressure dew point must be at least 15 °C under ambient and medium temperature and may not exceed 3 °C. The protection class is only ensured when the plug is mounted properly. For detailed information, see operating instructions. Precision: Standard measurement range: $\pm 4\%$ of measured value, + 0.5% of final value. Extended measurement range: $\pm 8\%$ of measured value, + 1% of final value.



Technical data

Industry
Industrial

Note

Output signal: 1 analog output 4 mA ... 20 mA + 1 digital/ analog output (PNP, NPN, push-pull, 4 mA ... 20 mA / switchable)+1 digital output (PNP, NPN, push-pull, switchable), IO-Link V1.1 (COM3 / 230K4 baud)

Frame size
652

Switching principle

Flow measuring principle: calorimetric

Protocol
IO-Link

Nominal flow Q_n min., standard
8 l/min

Nominal flow Q_n max., standard
1630 l/min

Nominal flow Q_n min., extended
1630 l/min

Nominal flow Q_n max., extended
2445 l/min

Compressed air connection
G 1/2

Certificates
CE declaration of conformity

RoHS

Working pressure min.
0 bar

Working pressure max
16 bar

Min. ambient temperature
-20 °C

Max. ambient temperature
50 °C

Min. medium temperature
-20 °C

Max. medium temperature
50 °C

Medium

Compressed air
Argon
Nitrogen
Helium
Carbon dioxide

filter porosity
5 μ m

Display
OLED

Flow display unit
l/sec
l/min

m ³ /min m ³ /h ft ³ /s m ³ /min	Power consumption max. 12 W
Pressure display unit bar psi	Operating voltage DC, min. 17 V DC Operating voltage DC, max. 30 V DC
Temperature display unit °C °F	Response time < 0.3 s
Electrical connection Plug	Short circuit resistance short circuit resistant
Electrical connection M12x1	Shock resistance max. 30 g, 11 ms
Electrical connection 5-pin	Vibration resistance 1 g (10 - 2000 Hz) IEC 60068 - 2-6
Electrical connection A-coded	Reproducibility ± 1.5% of the measured value
Output signal digital PNP/NPN/push-pull, switchable	Protection class IP65 IP67 according to IEC 60529
Output signal analog 4 ... 20 mA	Weight 0.73 kg

Material

Housing material
Polyamide
Polycarbonate
Aluminum

Seal material filter
Nitrile butadiene rubber

Seal material sensor
Fluorocarbon caoutchouc

Part No.
G652AVBP4JA000N

Dimensions in inches

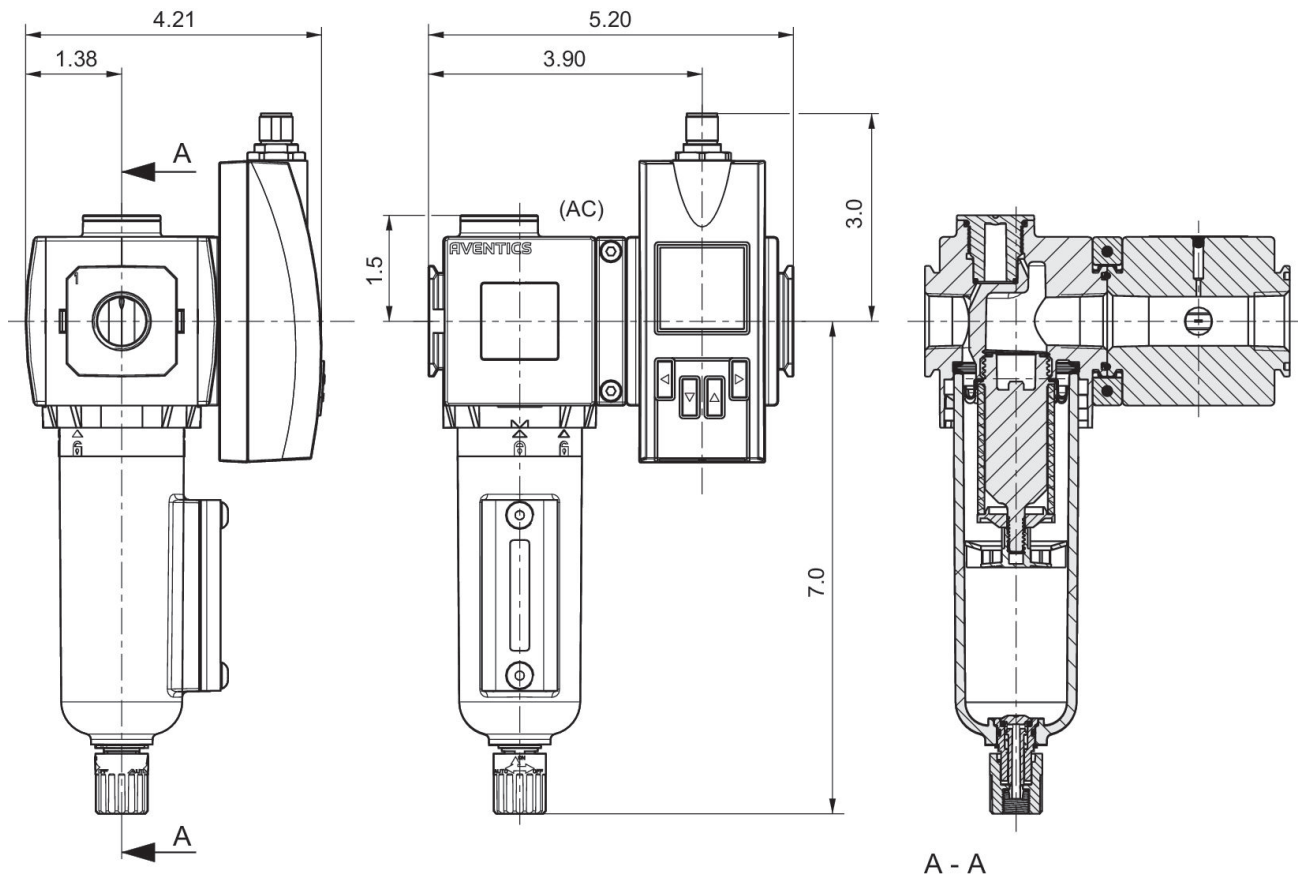

Dimensions in mm

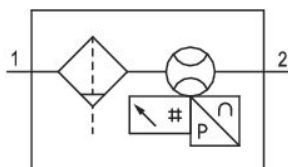
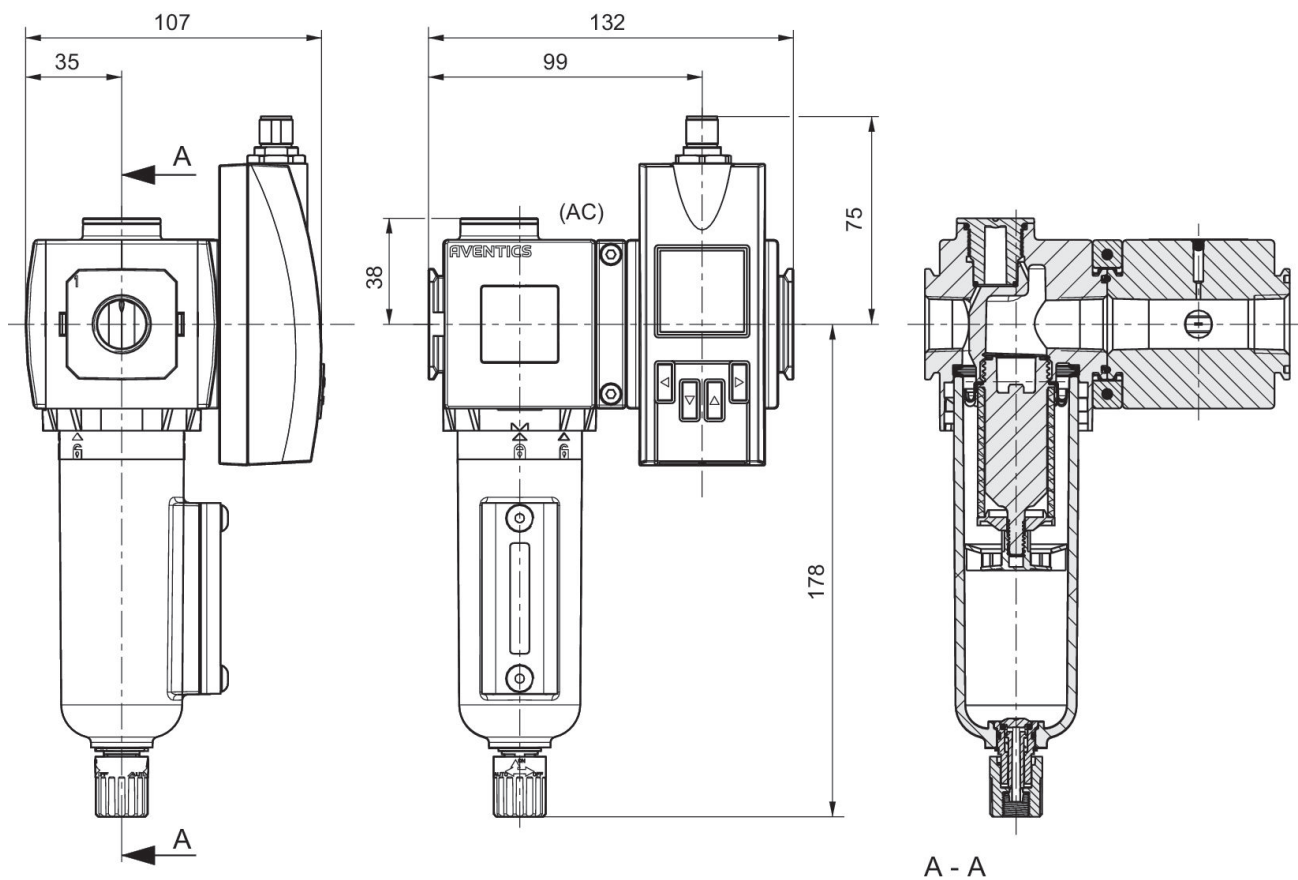

Pin assignments

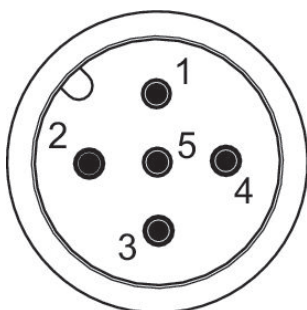

Pin	Allocation	Wire color	
1	L+	brown	Supply Voltage
2	QA (output 4 ... 20 mA)	white	
3	m = mass	blue	

Pin	Allocation	Wire color	
4	C/Q1 (IO-Link/switch output)	black	
5	Analog output 4 ... 20 mA	yellow	

Series AF2 flow sensor, 652 filter version, IO-Link

8652AVBP4JA000N

Series 652

- The pressure dew point must be at least 15 °C under ambient and medium temperature and may not exceed 3 °C. The protection class is only ensured when the plug is mounted properly. For detailed information, see operating instructions. Precision: Standard measurement range: $\pm 4\%$ of measured value, + 0.5% of final value. Extended measurement range: $\pm 8\%$ of measured value, + 1% of final value.



Technical data

Industry
Industrial

Frame size
652

Switching principle
Flow measuring principle: calorimetric

Protocol
IO-Link

Nominal flow Q_n min., standard
8 l/min

Nominal flow Q_n max., standard
1630 l/min

Nominal flow Q_n min., extended
1630 l/min

Nominal flow Q_n max., extended
2445 l/min

Compressed air connection
1/2 NPT

Certificates
CE declaration of conformity
RoHS

Working pressure min.
0 bar

Working pressure max
16 bar

Min. ambient temperature
-20 °C

Max. ambient temperature
50 °C

Min. medium temperature
-20 °C

Max. medium temperature
50 °C

Medium
Compressed air
Argon
Nitrogen
Helium
Carbon dioxide

filter porosity
5 μm

Display
OLED

Flow display unit
l/sec
l/min
 m^3/min
 m^3/h
 ft^3/s

m ³ /min	Operating voltage DC, min. 17 V DC
Pressure display unit bar psi	Operating voltage DC, max. 30 V DC
Temperature display unit °C °F	Response time < 0.3 s
Electrical connection Plug	Short circuit resistance short circuit resistant
Electrical connection M12x1	Shock resistance max. 30 g, 11 ms
Electrical connection 5-pin	Vibration resistance 1 g (10 - 2000 Hz) IEC 60068 - 2-6
Electrical connection A-coded	Reproducibility ± 1.5% of the measured value
Output signal analog 4 ... 20 mA	Protection class IP65 IP67 according to IEC 60529
Power consumption max. 12 W	Weight 0.73 kg

Material

Housing material
Polyamide
Polycarbonate
Aluminum

Seal material filter
Nitrile butadiene rubber

Seal material sensor
Fluorocarbon caoutchouc

Part No.
8652AVBP4JA000N

Dimensions in inches

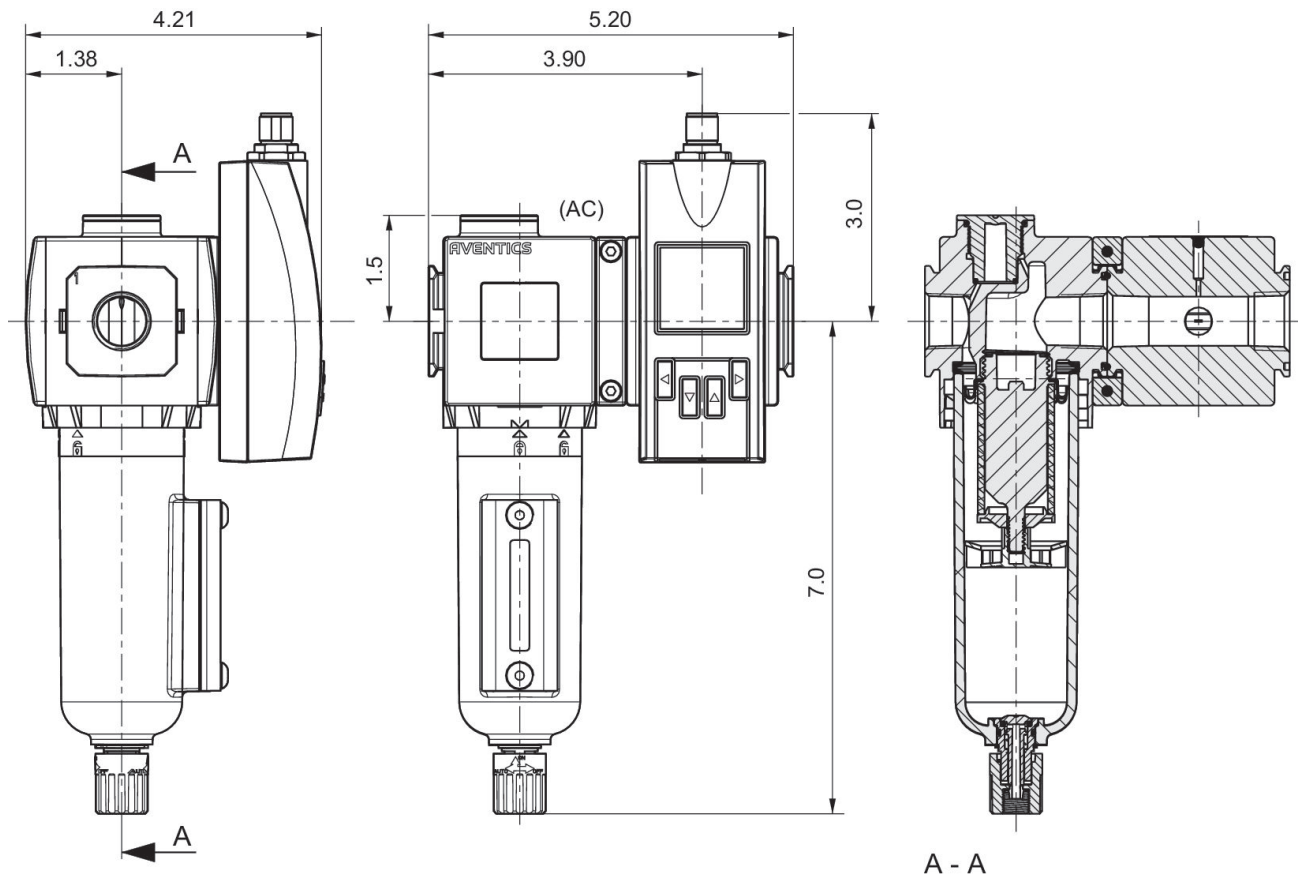

Dimensions in mm

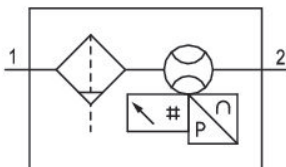
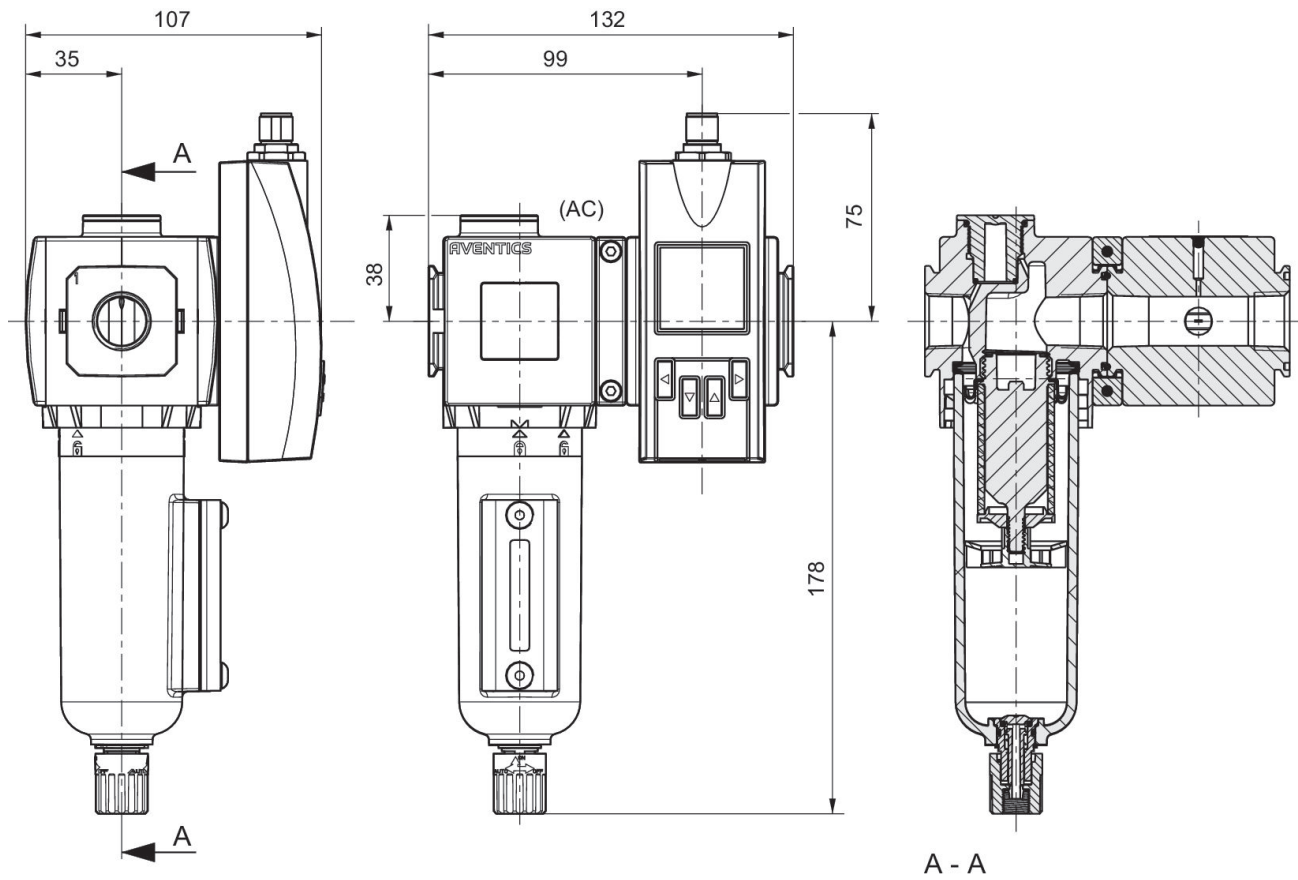

Pin assignments

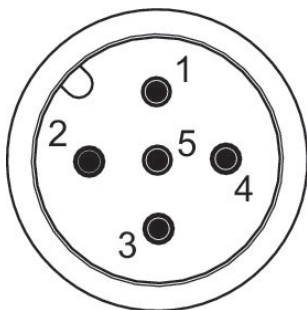

Pin	Allocation	Wire color	
1	L+	brown	Supply Voltage
2	QA (output 4 ... 20 mA)	white	
3	m = mass	blue	

Pin	Allocation	Wire color	
4	C/Q1 (IO-Link/switch output)	black	
5	Analog output 4 ... 20 mA	yellow	

Series AF2 flow sensor, 652 pipe version with pipe, Ethernet

G652AV004JA0010

Series 652

- The pressure dew point must be at least 15 °C under ambient and medium temperature and may not exceed 3 °C. The protection class is only ensured when the plug is mounted properly. For detailed information, see operating instructions. Liquid oil or water must be separated via prefiltering. If it is not separated sufficiently, drifting may result. Precision: Standard measurement range: $\pm 3\%$ of measured value, + 0.3% of final value. Extended measurement range: $\pm 8\%$ of measured value, + 1% of final value.



Technical data

Industry
Industrial

Note
Integrated web server, 48 VDC connection via Power over Ethernet

Switching principle
Flow measuring principle: calorimetric

Protocol
TCP/IP
OPC UA
MQTT

Nominal flow Qn min., standard
5.3 l/min

Nominal flow Qn max., standard
1060 l/min

Nominal flow Qn min., extended
1060 l/min

Nominal flow Qn max., extended
1590 l/min

Compressed air connection
G 1/2

Certificates
CE declaration of conformity
RoHS

Working pressure min.
0 bar

Working pressure max
16 bar

Min. ambient temperature
-20 °C

Max. ambient temperature
60 °C

Min. medium temperature
-20 °C

Max. medium temperature
60 °C

Medium
Compressed air
Argon

Nitrogen
Helium
Carbon dioxide

Display
OLED

Flow display unit
l/sec
l/min
m³/min
m³/h
ft³/s
m³/min

Pressure display unit
bar
psi

Temperature display unit
°C
°F

Electrical connection
Plug

Electrical connection
M12x1

Electrical connection
8-pin

Power consumption max.
5 W

Operating voltage DC, min.
36 V DC

Operating voltage DC, max.
57 V DC

Response time
< 0.3 s

Shock resistance max.
30 g, 11 ms

Vibration resistance
1 g (10 - 2000 Hz) IEC 60068 - 2-6

Reproducibility
± 1.5% of the measured value

Protection class
IP65
IP67 according to IEC 60529

Weight
0.805 kg

Material

Housing material
Polyamide
Polycarbonate
Aluminum

Pipe material
Stainless Steel

Seal material sensor
Fluorocarbon caoutchouc

Part No.
G652AV004JA0010

Dimensions in mm

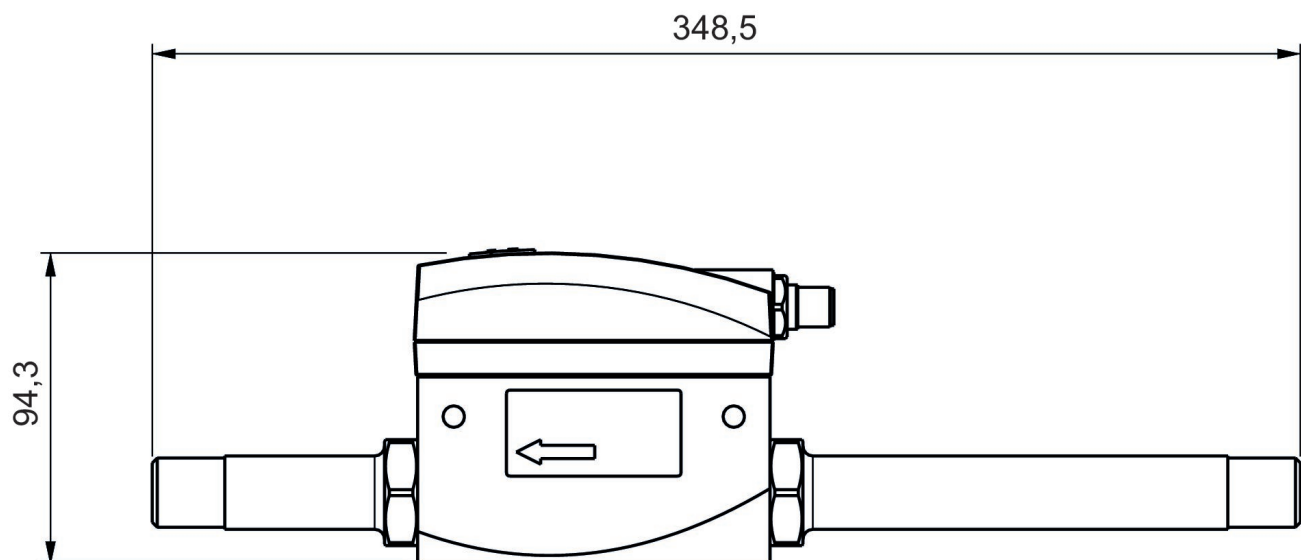

Dimensions in inches

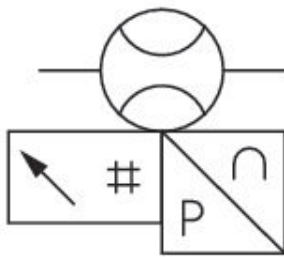
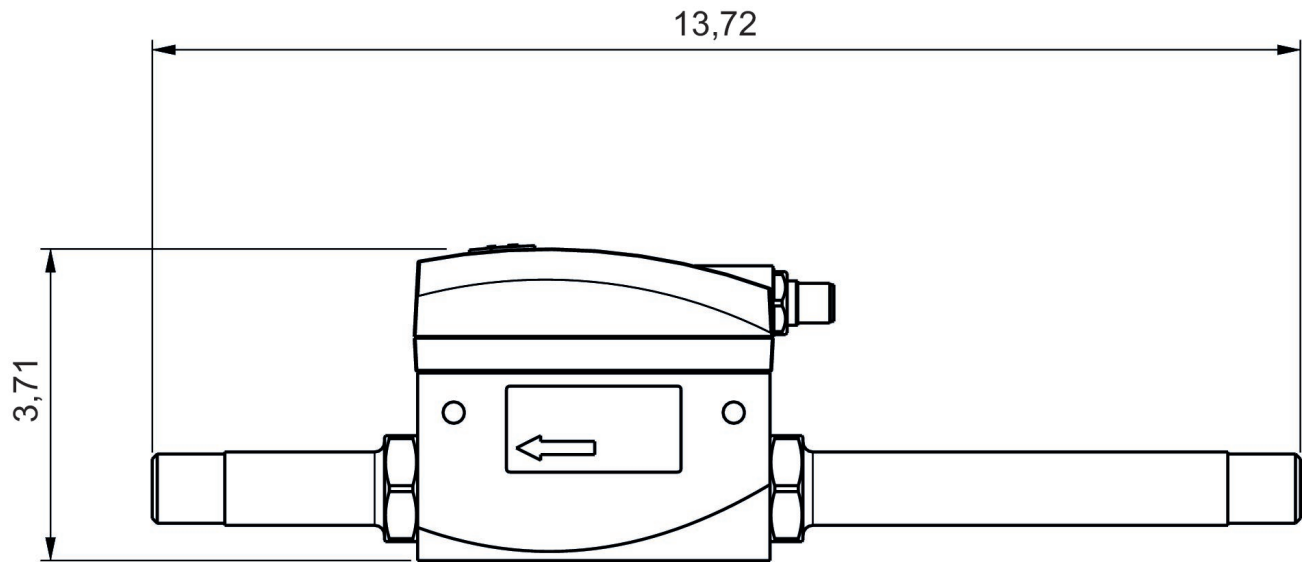

Pin assignments

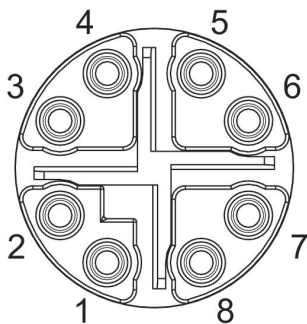

Pin	RJ45	Wire color	Identification	10/100 Mbit
1	1	WH / OG	TX(+) + POE	TxData+
2	2	OG	TX(-) + POE	TxData+
3	3	WH / GN	RX(+) - POE	TxData-
4	6	GN	RX(-) - POE	TxData-
7	5	WH / BU	POE+	
8	4	BU	POE+	
5	7	WH / BN	POE-	
6	8	BN	POE-	

Series AF2 flow sensor, 652 pipe version with pipe, Ethernet

8652AV004JA0010

Series 652

- The pressure dew point must be at least 15 °C under ambient and medium temperature and may not exceed 3 °C. The protection class is only ensured when the plug is mounted properly. For detailed information, see operating instructions. Liquid oil or water must be separated via prefiltering. If it is not separated sufficiently, drifting may result. Precision: Standard measurement range: $\pm 3\%$ of measured value, + 0.3% of final value. Extended measurement range: $\pm 8\%$ of measured value, + 1% of final value.



Technical data

Industry
Industrial

Note

Integrated web server, 48 VDC connection via Power over Ethernet

Switching principle

Flow measuring principle: calorimetric

Protocol

TCP/IP
OPC UA
MQTT

Nominal flow Qn min., standard
5.3 l/min

Nominal flow Qn max., standard
1060 l/min

Nominal flow Qn min., extended
1060 l/min

Nominal flow Qn max., extended
1590 l/min

Compressed air connection
1/2 NPT

Certificates

CE declaration of conformity
RoHS

Working pressure min.
0 bar

Working pressure max
16 bar

Min. ambient temperature
-20 °C

Max. ambient temperature
60 °C

Min. medium temperature
-20 °C

Max. medium temperature
60 °C

Medium
Compressed air
Argon

Nitrogen
Helium
Carbon dioxide

Display
OLED

Flow display unit
l/sec
l/min
m³/min
m³/h
ft³/s
m³/min

Pressure display unit
bar
psi

Temperature display unit
°C
°F

Electrical connection
Plug

Electrical connection
M12x1

Electrical connection
8-pin

Power consumption max.
5 W

Operating voltage DC, min.
36 V DC

Operating voltage DC, max.
57 V DC

Response time
< 0.3 s

Shock resistance max.
30 g, 11 ms

Vibration resistance
1 g (10 - 2000 Hz) IEC 60068 - 2-6

Reproducibility
± 1.5% of the measured value

Protection class
IP65
IP67 according to IEC 60529

Weight
0.805 kg

Material

Housing material
Polyamide
Polycarbonate
Aluminum

Pipe material
Stainless Steel

Seal material sensor
Fluorocarbon caoutchouc

Part No.
8652AV004JA0010

Dimensions in mm

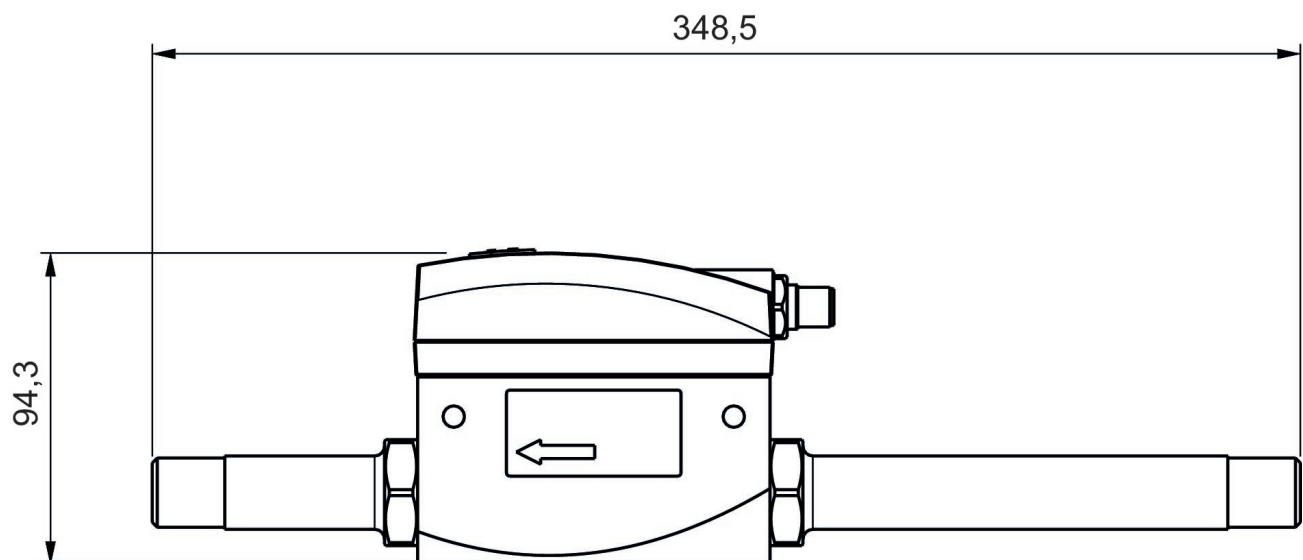

Dimensions in inches

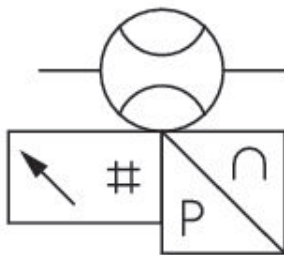
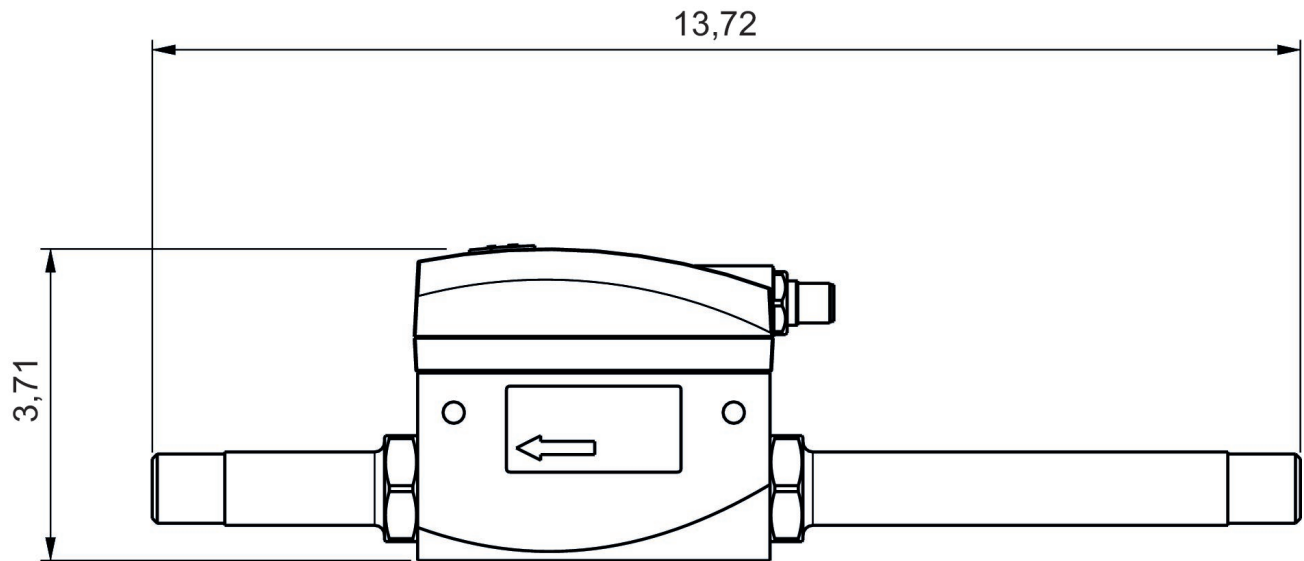

Pin assignments

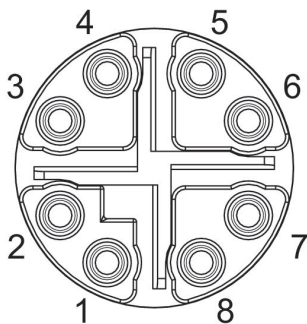

Pin	RJ45	Wire color	Identification	10/100 Mbit
1	1	WH / OG	TX(+) + POE	TxData+
2	2	OG	TX(-) + POE	TxData+
3	3	WH / GN	RX(+) - POE	TxData-
4	6	GN	RX(-) - POE	TxData-
7	5	WH / BU	POE+	
8	4	BU	POE+	
5	7	WH / BN	POE-	
6	8	BN	POE-	

Series AF2 flow sensor, 652 pipe version with pipe, IO-Link

8652AV004JA0000

Series 652

- The pressure dew point must be at least 15 °C under ambient and medium temperature and may not exceed 3 °C. The protection class is only ensured when the plug is mounted properly. For detailed information, see operating instructions. Liquid oil or water must be separated via prefiltering. If it is not separated sufficiently, drifting may result. Precision: Standard measurement range: $\pm 3\%$ of measured value, + 0.3% of final value. Extended measurement range: $\pm 8\%$ of measured value, + 1% of final value.



Technical data

Industry
Industrial

Note

Output signal: 1 analog output 4 mA ... 20 mA + 1 digital/ analog output (PNP, NPN, push-pull, 4 mA ... 20 mA / switchable)+1 digital output (PNP, NPN, push-pull, switchable), IO-Link V1.1 (COM3 / 230K4 baud)

Switching principle

Flow measuring principle: calorimetric

Protocol

IO-Link

Nominal flow Qn min., standard
5.3 l/min

Nominal flow Qn max., standard
1060 l/min

Nominal flow Qn min., extended
1060 l/min

Nominal flow Qn max., extended
1590 l/min

Compressed air connection
1/2 NPT

Certificates

CE declaration of conformity
RoHS

Working pressure min.
0 bar

Working pressure max
16 bar

Min. ambient temperature
-20 °C

Max. ambient temperature
60 °C

Min. medium temperature
-20 °C

Max. medium temperature
60 °C

Medium
Compressed air
Argon

Nitrogen	Output signal digital
Helium	PNP/NPN/push-pull, switchable
Carbon dioxide	
Display	Output signal analog
OLED	4 ... 20 mA
Flow display unit	Power consumption max.
l/sec	12 W
l/min	Operating voltage DC, min.
m ³ /min	17 V DC
m ³ /h	Operating voltage DC, max.
ft ³ /s	30 V DC
m ³ /min	
Pressure display unit	Response time
bar	< 0.3 s
psi	
Temperature display unit	Short circuit resistance
°C	short circuit resistant
°F	
Electrical connection	Shock resistance max.
Plug	30 g, 11 ms
Electrical connection	Vibration resistance
M12x1	1 g (10 - 2000 Hz) IEC 60068 - 2-6
Electrical connection	Reproducibility
5-pin	± 1.5% of the measured value
Electrical connection	Protection class
A-coded	IP65
	IP67 according to IEC 60529
	Weight
	0.805 kg

Material

Housing material

Polyamide
Polycarbonate
Aluminum

Pipe material

Stainless Steel

Seal material sensor

Fluorocarbon caoutchouc

Part No.

8652AV004JA0000

Dimensions in mm

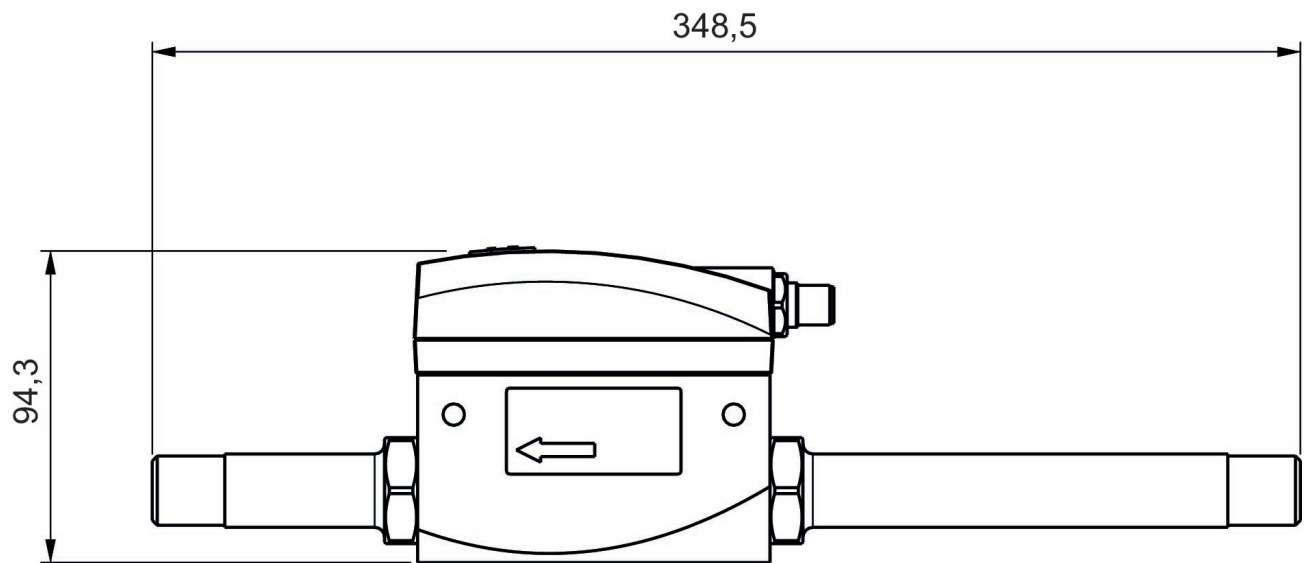

Dimensions in inches

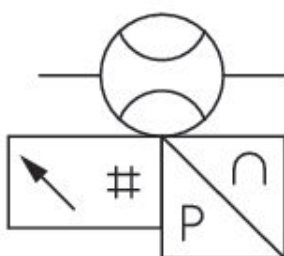
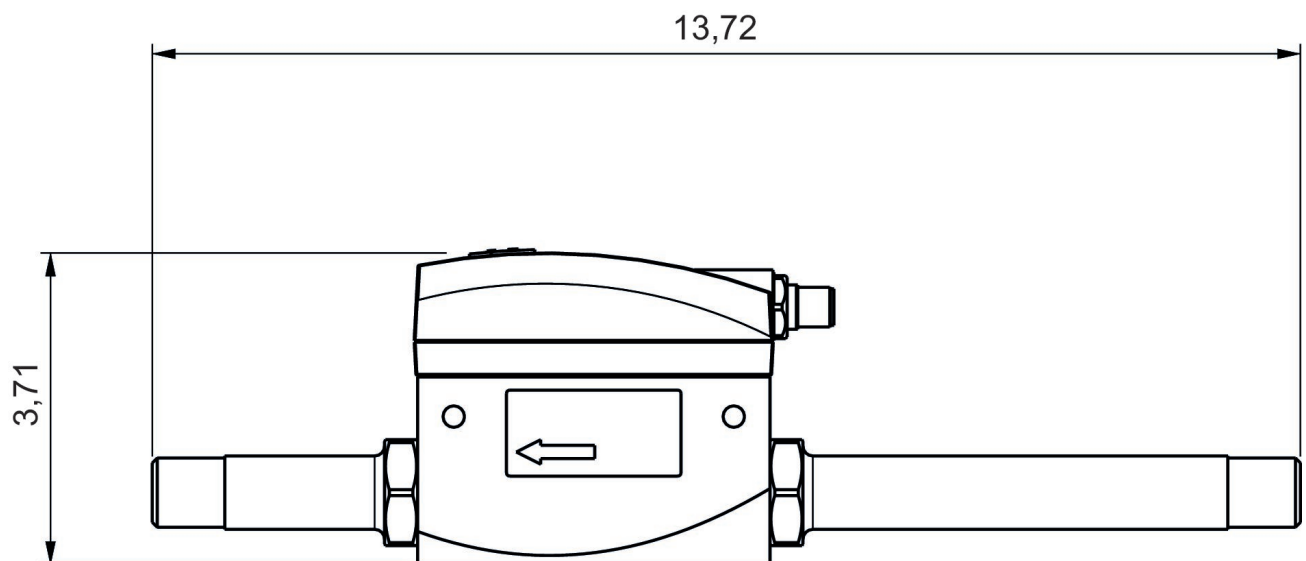

Pin assignments

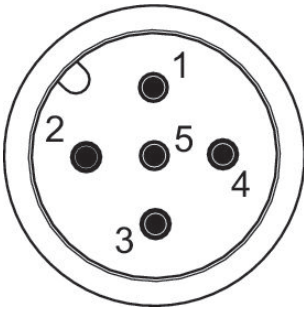

Pin	Allocation	Wire color	
1	L+	brown	Supply Voltage
2	QA (output 4 ... 20 mA)	white	
3	m = mass	blue	
4	C/Q1 (IO-Link/switch output)	black	
5	Analog output 4 ... 20 mA	yellow	

Series AF2 flow sensor, 652 pipe version with pipe, IO-Link

G652AV004JA0000

Series 652

- The pressure dew point must be at least 15 °C under ambient and medium temperature and may not exceed 3 °C. The protection class is only ensured when the plug is mounted properly. For detailed information, see operating instructions. Liquid oil or water must be separated via prefiltering. If it is not separated sufficiently, drifting may result. Precision: Standard measurement range: $\pm 3\%$ of measured value, + 0.3% of final value. Extended measurement range: $\pm 8\%$ of measured value, + 1% of final value.



Technical data

Industry
Industrial

Note

Output signal: 1 analog output 4 mA ... 20 mA + 1 digital/ analog output (PNP, NPN, push-pull, 4 mA ... 20 mA / switchable)+1 digital output (PNP, NPN, push-pull, switchable), IO-Link V1.1 (COM3 / 230K4 baud)

Switching principle

Flow measuring principle: calorimetric

Protocol

IO-Link

Nominal flow Q_n min., standard
5.3 l/min

Nominal flow Q_n max., standard
1060 l/min

Nominal flow Q_n min., extended
1060 l/min

Nominal flow Q_n max., extended
1590 l/min

Compressed air connection
G 1/2

Certificates

CE declaration of conformity
RoHS

Working pressure min.
0 bar

Working pressure max
16 bar

Min. ambient temperature
-20 °C

Max. ambient temperature
60 °C

Min. medium temperature
-20 °C

Max. medium temperature
60 °C

Medium
Compressed air
Argon

Nitrogen	Output signal digital
Helium	PNP, NPN, push-pull, 1x IO-Link
Carbon dioxide	
Display	Output signal analog
OLED	4 ... 20 mA
Flow display unit	Power consumption max.
l/sec	12 W
l/min	Operating voltage DC, min.
m ³ /min	17 V DC
m ³ /h	Operating voltage DC, max.
ft ³ /s	30 V DC
m ³ /min	
Pressure display unit	Response time
bar	< 0.3 s
psi	
Temperature display unit	Short circuit resistance
°C	short circuit resistant
°F	Shock resistance max.
	30 g, 11 ms
Electrical connection	Vibration resistance
Plug	1 g (10 - 2000 Hz) IEC 60068 - 2-6
Electrical connection	Reproducibility
M12x1	± 1.5% of the measured value
Electrical connection	Protection class
5-pin	IP65
Electrical connection	IP67 according to IEC 60529
A-coded	Weight
	0.805 kg

Material

Housing material

Polyamide
Polycarbonate
Aluminum

Pipe material

Stainless Steel

Seal material sensor

Fluorocarbon caoutchouc

Part No.

G652AV004JA0000

Dimensions in mm

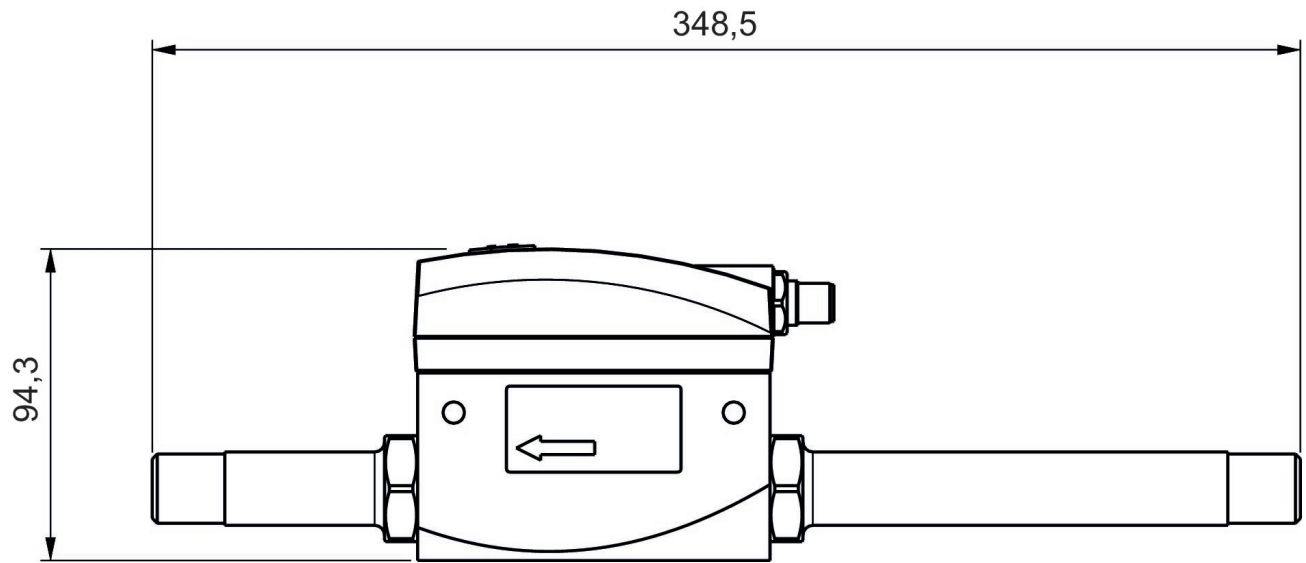

Dimensions in inches

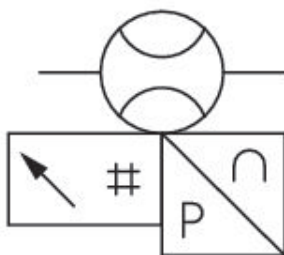
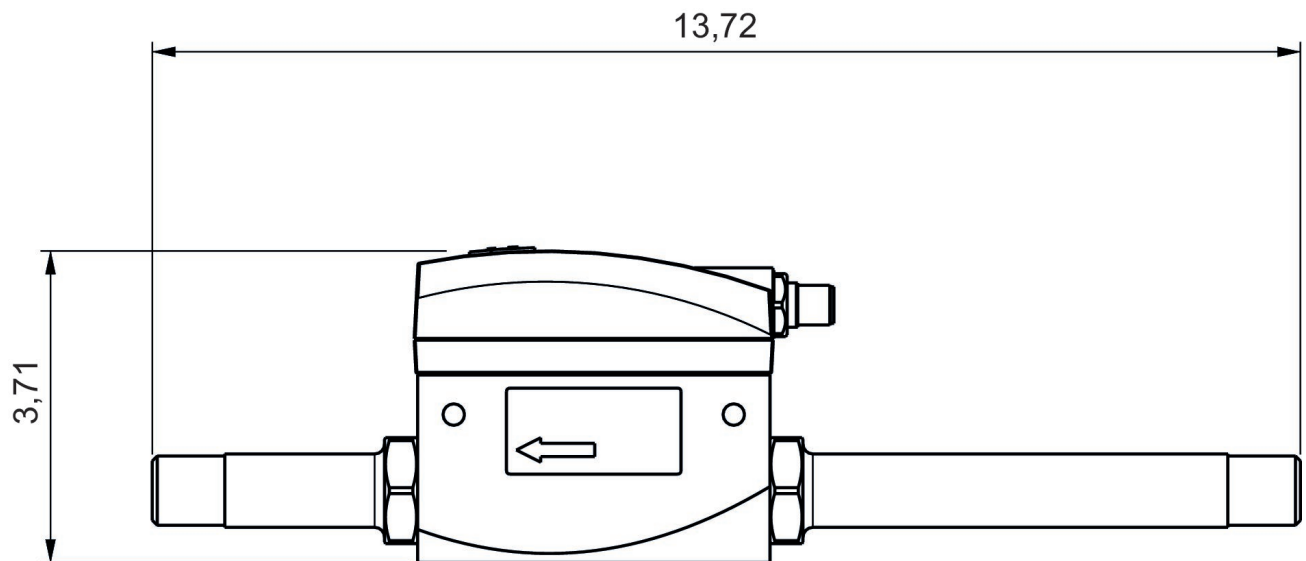

Pin assignments

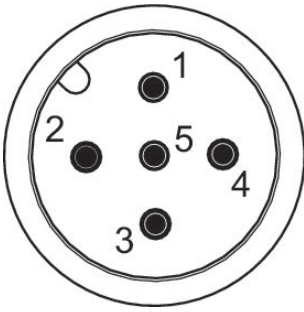

Pin	Allocation	Wire color	
1	L+	brown	Supply Voltage
2	QA (output 4 ... 20 mA)	white	
3	m = mass	blue	
4	C/Q1 (IO-Link/switch output)	black	
5	Analog output 4 ... 20 mA	yellow	

Series AF2 flow sensor, 653 pipe version with pipe, IO-Link

G653AV006JA0000

Series 653

- The pressure dew point must be at least 15 °C under ambient and medium temperature and may not exceed 3 °C. The protection class is only ensured when the plug is mounted properly. For detailed information, see operating instructions. Liquid oil or water must be separated via prefiltering. If it is not separated sufficiently, drifting may result. Precision: Standard measurement range: $\pm 3\%$ of measured value, + 0.3% of final value. Extended measurement range: $\pm 8\%$ of measured value, + 1% of final value.



Technical data

Industry
Industrial

Note

Output signal: 1 analog output 4 mA ... 20 mA + 1 digital/ analog output (PNP, NPN, push-pull, 4 mA ... 20 mA / switchable)+1 digital output (PNP, NPN, push-pull, switchable), IO-Link V1.1 (COM3 / 230K4 baud)

Switching principle

Flow measuring principle: calorimetric

Protocol

IO-Link

Nominal flow Q_n min., standard
14.7 l/min

Nominal flow Q_n max., standard
2945 l/min

Nominal flow Q_n min., extended
2945 l/min

Nominal flow Q_n max., extended
4417 l/min

Compressed air connection
G 1"

Certificates

CE declaration of conformity
RoHS

Working pressure min.
0 bar

Working pressure max
16 bar

Min. ambient temperature
-20 °C

Max. ambient temperature
60 °C

Min. medium temperature
-20 °C

Max. medium temperature
60 °C

Medium
Compressed air
Argon

Nitrogen	Output signal digital
Helium	PNP, NPN, push-pull, 1x IO-Link
Carbon dioxide	
Display	Output signal analog
OLED	4 ... 20 mA
Flow display unit	Power consumption max.
l/sec	5 W
l/min	Operating voltage DC, min.
m ³ /min	17 V DC
m ³ /h	Operating voltage DC, max.
ft ³ /s	30 V DC
m ³ /min	
Pressure display unit	Response time
bar	< 0.3 s
psi	
Temperature display unit	Short circuit resistance
°C	short circuit resistant
°F	Shock resistance max.
Electrical connection	30 g, 11 ms
Plug	Vibration resistance
Electrical connection	1 g (10 - 2000 Hz) IEC 60068 - 2-6
M12x1	Reproducibility
Electrical connection	± 1.5% of the measured value
5-pin	Protection class
Electrical connection	IP65
A-coded	IP67 according to IEC 60529
	Weight
	0.685 kg

Material

Housing material

Polyamide
Polycarbonate
Aluminum

Pipe material

Stainless Steel

Seal material sensor

Fluorocarbon caoutchouc

Part No.

G653AV006JA0000

Dimensions in mm

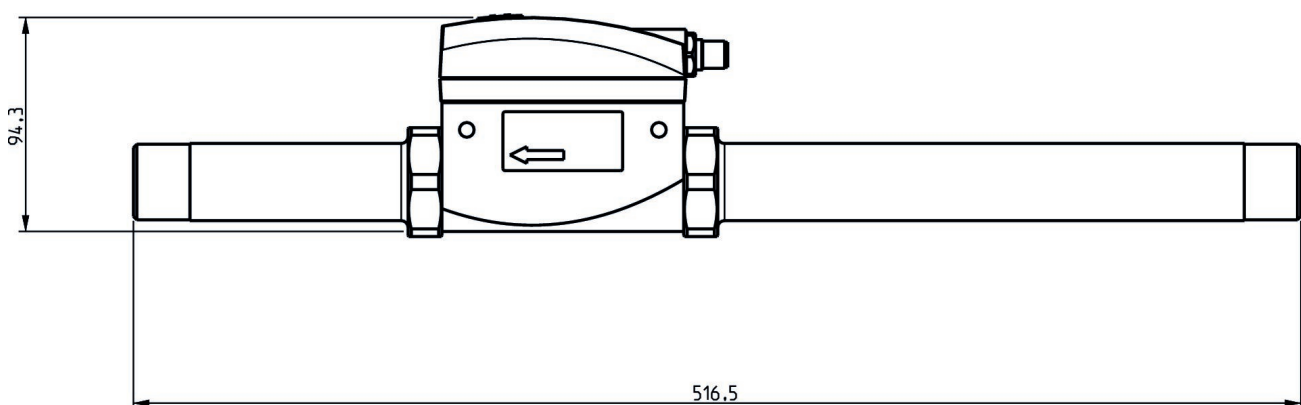

Dimensions in inches

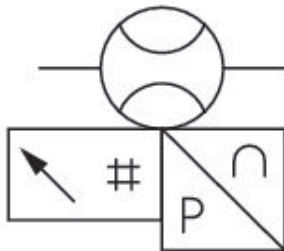
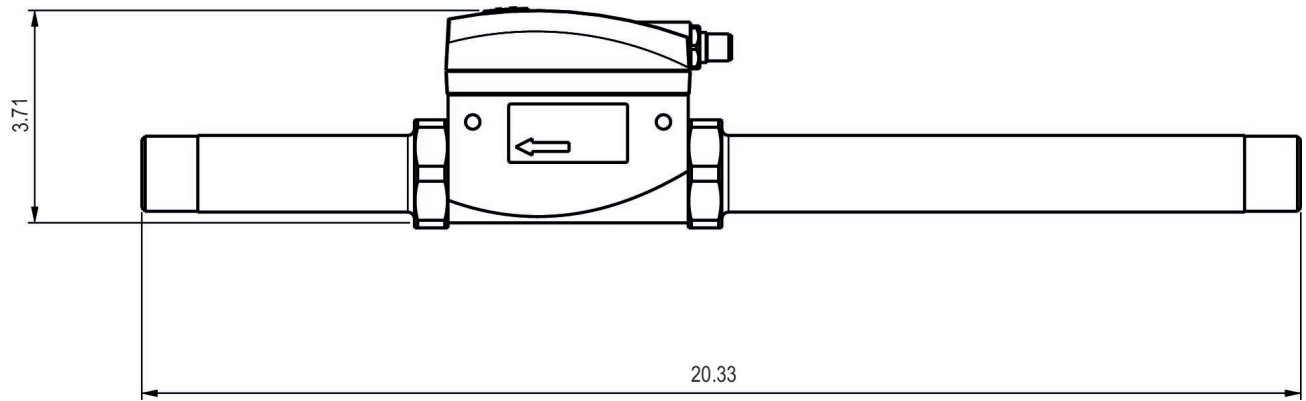

Pin assignments

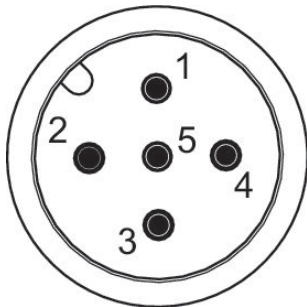

Pin	Allocation	Wire color	
1	L+	brown	Supply Voltage
2	QA (output 4 ... 20 mA)	white	
3	m = mass	blue	
4	C/Q1 (IO-Link/switch output)	black	
5	Analog output 4 ... 20 mA	yellow	

Series AF2 flow sensor, 653 pipe version with pipe, IO-Link

8653AV006JA0000

Series 653

- The pressure dew point must be at least 15 °C under ambient and medium temperature and may not exceed 3 °C. The protection class is only ensured when the plug is mounted properly. For detailed information, see operating instructions. Liquid oil or water must be separated via prefiltering. If it is not separated sufficiently, drifting may result. Precision: Standard measurement range: $\pm 3\%$ of measured value, + 0.3% of final value. Extended measurement range: $\pm 8\%$ of measured value, + 1% of final value.



Technical data

Industry
Industrial

Note

Output signal: 1 analog output 4 mA ... 20 mA + 1 digital/ analog output (PNP, NPN, push-pull, 4 mA ... 20 mA / switchable)+1 digital output (PNP, NPN, push-pull, switchable), IO-Link V1.1 (COM3 / 230K4 baud)

Switching principle

Flow measuring principle: calorimetric

Protocol

IO-Link

Nominal flow Qn min., standard
14.7 l/min

Nominal flow Qn max., standard
2945 l/min

Nominal flow Qn min., extended
2945 l/min

Nominal flow Qn max., extended
4417 l/min

Compressed air connection
1" NPT

Certificates

CE declaration of conformity
RoHS

Working pressure min.
0 bar

Working pressure max
16 bar

Min. ambient temperature
-20 °C

Max. ambient temperature
60 °C

Min. medium temperature
-20 °C

Max. medium temperature
60 °C

Medium
Compressed air
Argon

Nitrogen	Output signal digital
Helium	PNP, NPN, push-pull, 1x IO-Link
Carbon dioxide	
Display	Output signal analog
OLED	4 ... 20 mA
Flow display unit	Power consumption max.
l/sec	5 W
l/min	Operating voltage DC, min.
m ³ /min	17 V DC
m ³ /h	Operating voltage DC, max.
ft ³ /s	30 V DC
m ³ /min	
Pressure display unit	Response time
bar	< 0.3 s
psi	
Temperature display unit	Short circuit resistance
°C	short circuit resistant
°F	Shock resistance max.
Electrical connection	30 g, 11 ms
Plug	Vibration resistance
Electrical connection	1 g (10 - 2000 Hz) IEC 60068 - 2-6
M12x1	Reproducibility
Electrical connection	± 1.5% of the measured value
5-pin	Protection class
Electrical connection	IP65
A-coded	IP67 according to IEC 60529
	Weight
	0.685 kg

Material

Housing material

Polyamide
Polycarbonate
Aluminum

Pipe material

Stainless Steel

Seal material sensor

Fluorocarbon caoutchouc

Part No.

8653AV006JA0000

Dimensions in mm

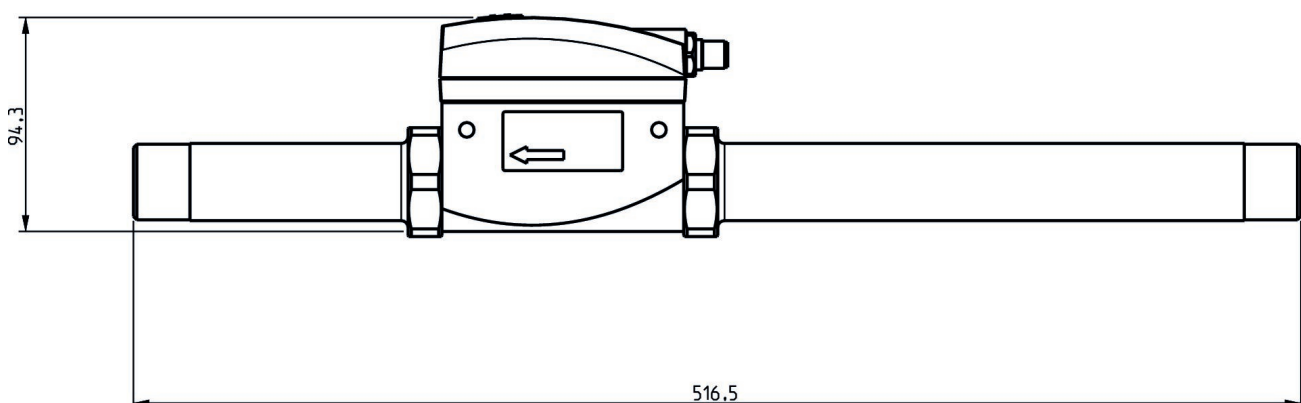

Dimensions in inches

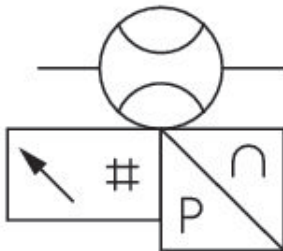
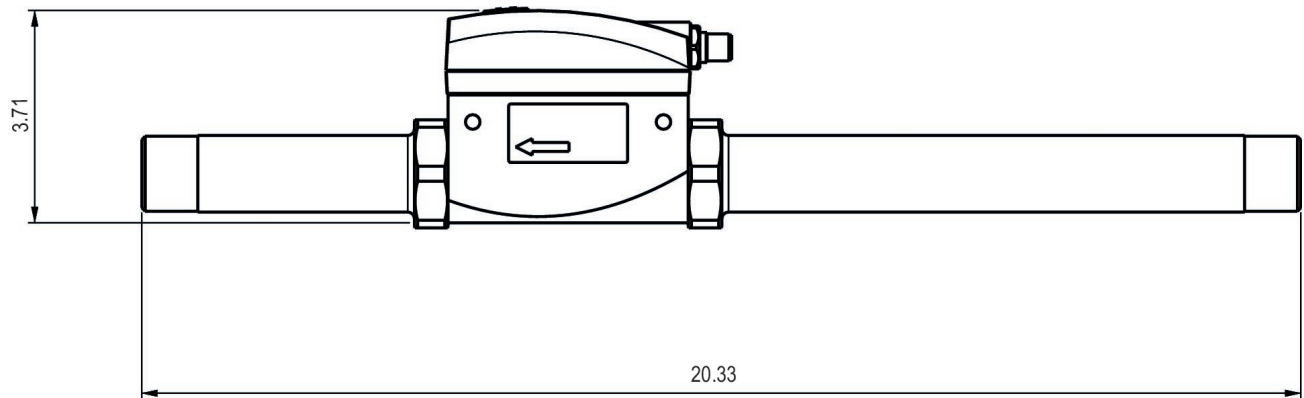

Pin assignments

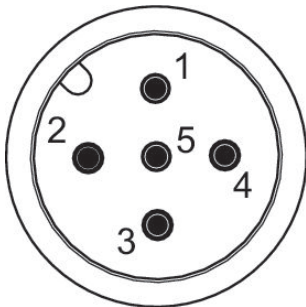

Pin	Allocation	Wire color	
1	L+	brown	Supply Voltage
2	QA (output 4 ... 20 mA)	white	
3	m = mass	blue	
4	C/Q1 (IO-Link/switch output)	black	
5	Analog output 4 ... 20 mA	yellow	

Series AF2 flow sensor, 653 pipe version with pipe, Ethernet

G653AV006JA0010

Series 653

- The pressure dew point must be at least 15 °C under ambient and medium temperature and may not exceed 3 °C. The protection class is only ensured when the plug is mounted properly. For detailed information, see operating instructions. Liquid oil or water must be separated via prefiltering. If it is not separated sufficiently, drifting may result. Precision: Standard measurement range: $\pm 3\%$ of measured value, + 0.3% of final value. Extended measurement range: $\pm 8\%$ of measured value, + 1% of final value.



Technical data

Industry
Industrial

Note
Integrated web server, 48 VDC connection via Power over Ethernet

Switching principle
Flow measuring principle: calorimetric

Protocol
TCP/IP
OPC UA
MQTT

Nominal flow Q_n min., extended
2945 l/min

Nominal flow Q_n max., extended
4417 l/min

Compressed air connection
G 1"

Certificates
CE declaration of conformity
RoHS

Working pressure min.
0 bar

Working pressure max
16 bar

Min. ambient temperature
-20 °C

Max. ambient temperature
60 °C

Min. medium temperature
-20 °C

Max. medium temperature
60 °C

Medium
Compressed air
Argon
Nitrogen
Helium
Carbon dioxide

Display
OLED

Flow display unit

l/sec
l/min
m³/min
m³/h
ft³/s
m³/min

Pressure display unit

bar
psi

Temperature display unit

°C
°F

Electrical connection

Plug

Electrical connection

M12x1

Electrical connection

8-pin

Electrical connection

X-coded

Power consumption max.

5 W

Operating voltage DC, min.

36 V DC

Operating voltage DC, max.

57 V DC

Response time

< 0.3 s

Short circuit resistance

short circuit resistant

Shock resistance max.

30 g, 11 ms

Vibration resistance

1 g (10 - 2000 Hz) IEC 60068 - 2-6

Reproducibility

± 1.5% of the measured value

Protection class

IP65

IP67 according to IEC 60529

Weight

0.685 kg

Material

Housing material

Polyamide
Polycarbonate
Aluminum

Seal material sensor

Fluorocarbon caoutchouc

Pipe material

Stainless Steel

Part No.

G653AV006JA0010

Dimensions in mm

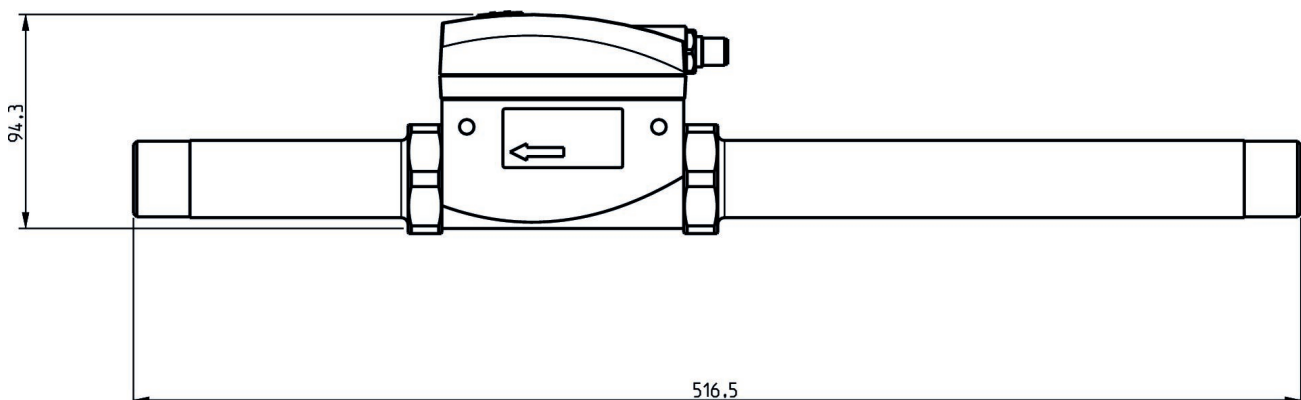

Dimensions in inches

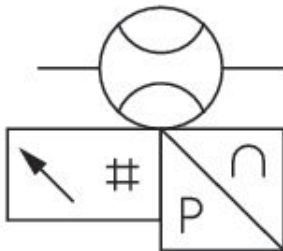
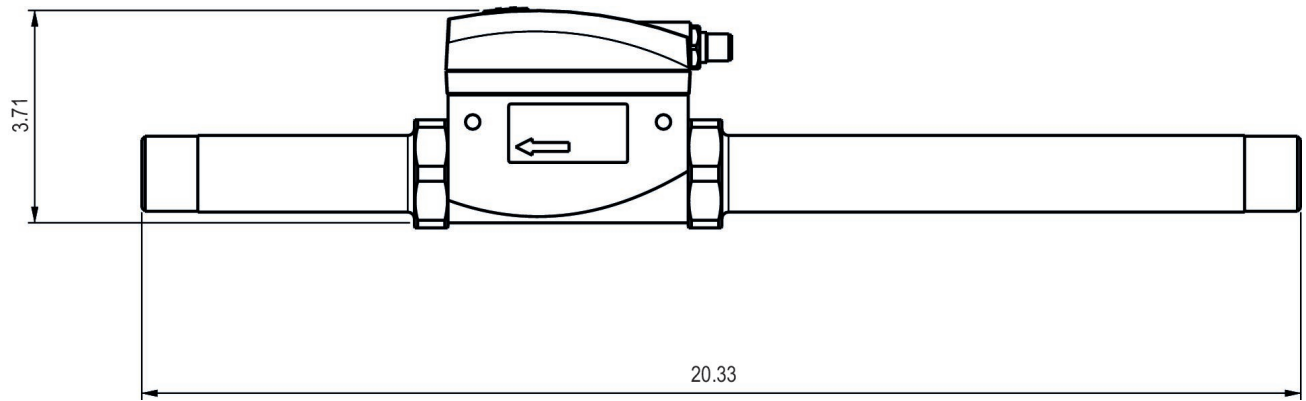

Pin assignments

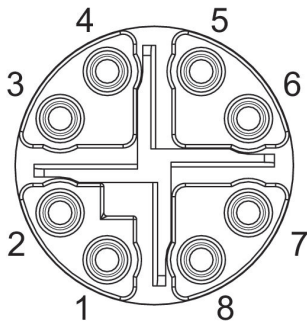

Pin	RJ45	Wire color	Identification	10/100 Mbit
1	1	WH / OG	TX(+) + POE	TxData+
2	2	OG	TX(-) + POE	TxData+
3	3	WH / GN	RX(+) - POE	TxData-
4	6	GN	RX(-) - POE	TxData-
7	5	WH / BU	POE+	
8	4	BU	POE+	
5	7	WH / BN	POE-	
6	8	BN	POE-	

Series AF2 flow sensor, 653 pipe version with pipe, Ethernet

8653AV006JA0010

Series 653

- The pressure dew point must be at least 15 °C under ambient and medium temperature and may not exceed 3 °C. The protection class is only ensured when the plug is mounted properly. For detailed information, see operating instructions. Liquid oil or water must be separated via prefiltering. If it is not separated sufficiently, drifting may result. Precision: Standard measurement range: $\pm 3\%$ of measured value, + 0.3% of final value. Extended measurement range: $\pm 8\%$ of measured value, + 1% of final value.



Technical data

Industry
Industrial

Note
Integrated web server, 48 VDC connection via Power over Ethernet

Switching principle
Flow measuring principle: calorimetric

Protocol
TCP/IP
OPC UA
MQTT

Nominal flow Qn min., extended
2945 l/min

Nominal flow Qn max., extended
4417 l/min

Compressed air connection
1" NPT

Certificates
CE declaration of conformity
RoHS

Working pressure min.
0 bar

Working pressure max
16 bar

Min. ambient temperature
-20 °C

Max. ambient temperature
60 °C

Min. medium temperature
-20 °C

Max. medium temperature
60 °C

Medium
Compressed air
Argon
Nitrogen
Helium
Carbon dioxide

Display
OLED

Flow display unit

l/sec
l/min
m³/min
m³/h
ft³/s
m³/min

Pressure display unit

bar
psi

Temperature display unit

°C
°F

Electrical connection

Plug

Electrical connection

M12x1

Electrical connection

8-pin

Electrical connection

X-coded

Power consumption max.

5 W

Operating voltage DC, min.

36 V DC

Operating voltage DC, max.

57 V DC

Response time

< 0.3 s

Short circuit resistance

short circuit resistant

Shock resistance max.

30 g, 11 ms

Vibration resistance

1 g (10 - 2000 Hz) IEC 60068 - 2-6

Reproducibility

± 1.5% of the measured value

Protection class

IP65

IP67 according to IEC 60529

Weight

0.685 kg

Material

Housing material

Polyamide
Polycarbonate
Aluminum

Seal material sensor

Fluorocarbon caoutchouc

Pipe material

Stainless Steel

Part No.

8653AV006JA0010

Dimensions in mm

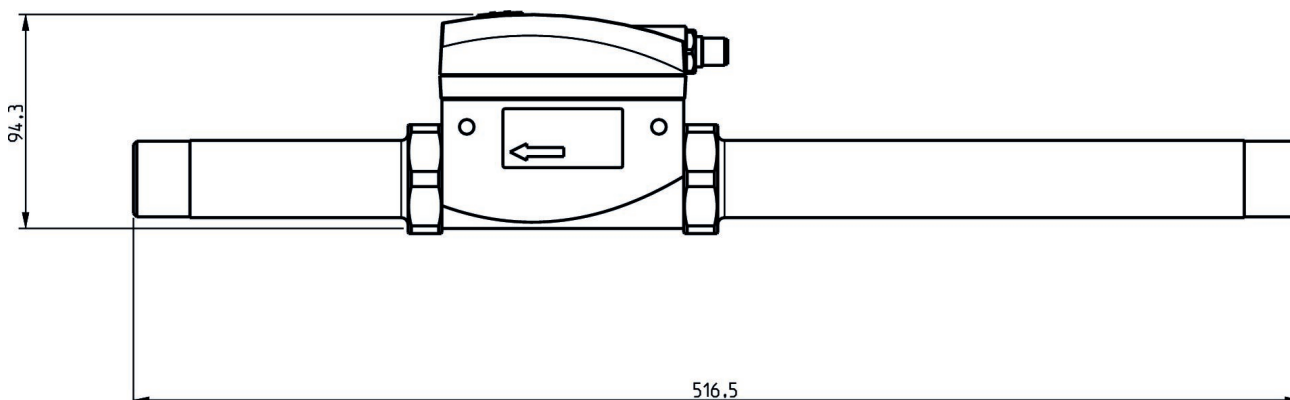

Dimensions in inches

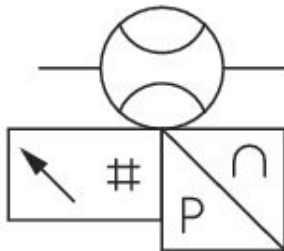
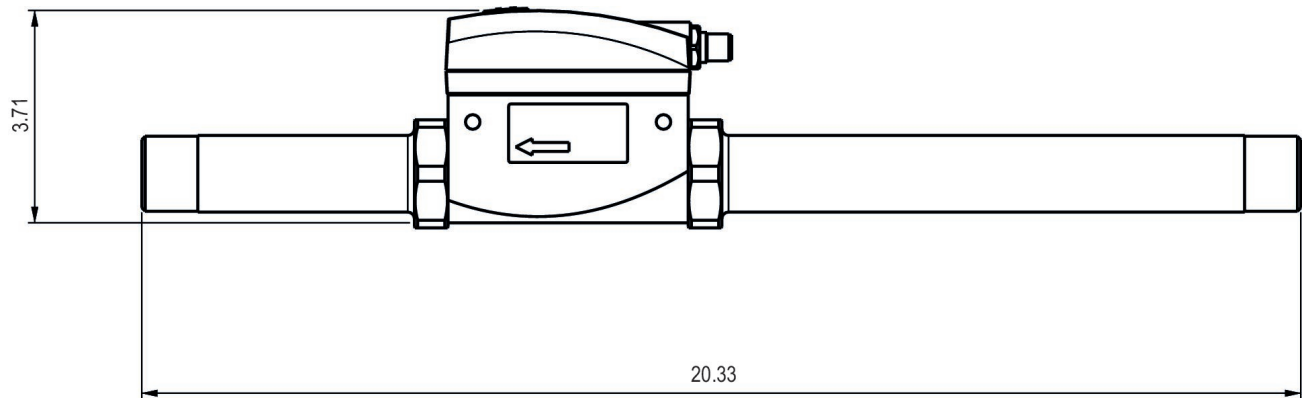

Pin assignments

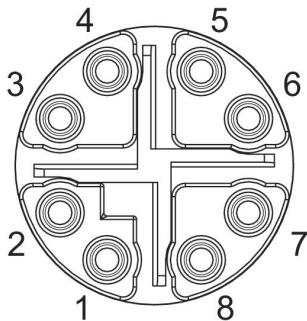

Pin	RJ45	Wire color	Identification	10/100 Mbit
1	1	WH / OG	TX(+) + POE	TxData+
2	2	OG	TX(-) + POE	TxData+
3	3	WH / GN	RX(+) - POE	TxData-
4	6	GN	RX(-) - POE	TxData-
7	5	WH / BU	POE+	
8	4	BU	POE+	
5	7	WH / BN	POE-	
6	8	BN	POE-	

Flow sensor, Ethernet, Series AF2-HF

R412028643

General series information Series AF2

- The AVENTICS Series AF2 are flow sensors that monitor air consumption in pneumatic systems, enabling rapid intervention in the event of leakage. The Series AF2 helps to optimize energy consumption, prevent machine downtime and cut costs.



Technical data

Industry
Industrial

Frame size
DN40

Switching principle
Flow measuring principle: calorimetric

Protocol
Ethernet

Compressed air connection
R 1 1/2

Certificates
CE declaration of conformity
RoHS

Working pressure min.
0 bar

Working pressure max
16 bar

Min. ambient temperature
-20 °C

Max. ambient temperature
60 °C

Min. medium temperature
-20 °C

Max. medium temperature
60 °C

Medium
Compressed air
Argon
Nitrogen
Helium
Carbon dioxide

Display
OLED

Flow display unit
l/sec
l/min
m³/min
m³/h
ft³/s
m³/min

Pressure display unit
bar
psi

Temperature display unit
°C
°F

Electrical connection 2, type
Plug

Electrical connection 2, thread size
M12x1

Electrical connection 2, number of poles
8-pin

Electrical connection 2, coding
X-coded

Power consumption max.
12 W

Operational voltage
24 V DC

Response time
< 0.3 s

Short circuit resistance
short circuit resistant

Shock resistance max.
30 g, 11 ms

Vibration resistance
1 g (10 - 2000 Hz) IEC 60068 - 2-6

Reproducibility
± 1.5% of the measured value

Protection class
IP65

IP67 according to IEC 60529

Weight
2.3 kg

Material

Housing material
Polyamide
Polycarbonate

Seal material
Fluorocautchouc

Part No.
R412028643

Technical information

The protection class is only ensured when the plug is mounted properly. For detailed information, see operating instructions.

Liquid oil or water must be separated via prefiltering. If it is not separated sufficiently, drifting may result.

Precision - Standard measurement range: ±6% of measured value, + 0.6% of final value- Extended measurement range: ±8% of measured value, + 0.8% of final value

Standard measurement range for flow measurement: compressed air 0.5 ... 100 m/s, extended measurement range: compressed air >100 ... 150 m/s, in accordance with ISO 8778

The pressure dew point must be at least 15 °C under ambient and medium temperature and may not exceed 3 °C .

The oil content of compressed air must remain constant during the life cycle.

Use only the approved oils from AVENTICS. Further information can be found in the "Technical information" document (available in <https://www.emerson.com/en-us/support>).

Dimensions in mm

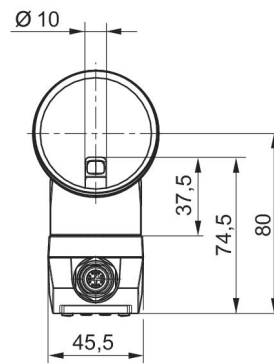
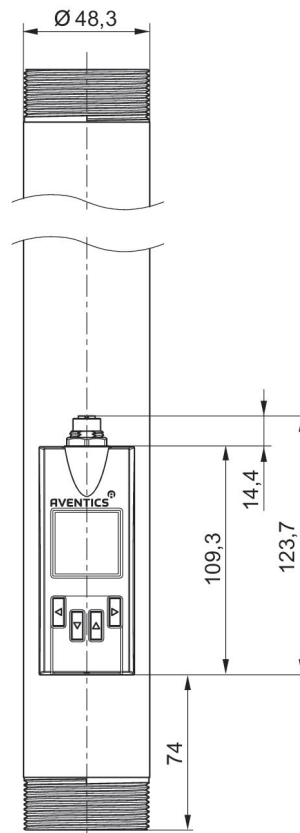
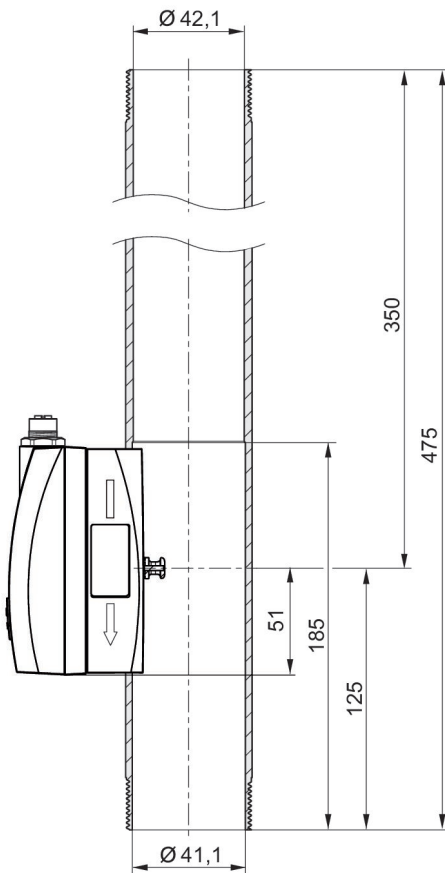

Pin assignments

M12x1 connection, 8-pin (X-coded) Ethernet

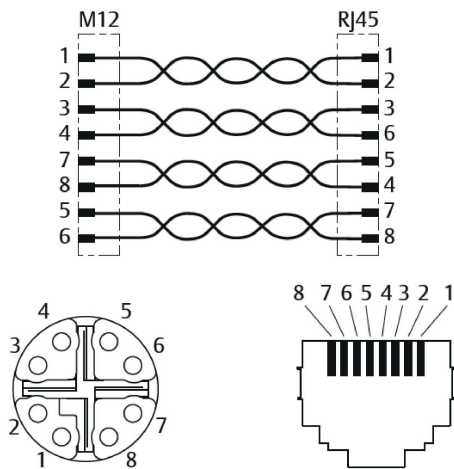

M12 x-coded	RJ45	Color	Function	10/100 Mbit
1	1	WH / OG	TX(+) + POE	TxData +
2	2	OG	TX(-) + POE	TxData -
3	3	WH / GN	RX(+) + POE	RxData +
4	4	GN	RX(-) + POE	RxData -
7	5	WH / BU	POE +	
8	6	BU	POE +	
5	7	WH / BN	POE -	
6	8	BN	POE -	

Flow sensor, Ethernet, Series AF2-HF

R412028645

General series information Series AF2

- The AVENTICS Series AF2 are flow sensors that monitor air consumption in pneumatic systems, enabling rapid intervention in the event of leakage. The Series AF2 helps to optimize energy consumption, prevent machine downtime and cut costs.



Technical data

Industry
Industrial

Frame size
DN40

Switching principle
Flow measuring principle: calorimetric

Protocol
Ethernet

Compressed air connection
1 1/2" NPT

Certificates
CE declaration of conformity
RoHS

Working pressure min.
0 bar

Working pressure max
16 bar

Min. ambient temperature
-20 °C

Max. ambient temperature
60 °C

Min. medium temperature
-20 °C

Max. medium temperature
60 °C

Medium
Compressed air
Argon
Nitrogen
Helium
Carbon dioxide

Display
OLED

Flow display unit
l/sec
l/min
m³/min
m³/h
ft³/s
m³/min

Pressure display unit
bar
psi

Temperature display unit
°C
°F

Electrical connection 2, type
Plug

Electrical connection 2, thread size
M12x1

Electrical connection 2, number of poles
8-pin

Electrical connection 2, coding
X-coded

Power consumption max.
12 W

Operational voltage
24 V DC

Response time
< 0.3 s

Short circuit resistance
short circuit resistant

Shock resistance max.
30 g, 11 ms

Vibration resistance
1 g (10 - 2000 Hz) IEC 60068 - 2-6

Reproducibility
± 1.5% of the measured value

Protection class
IP65

IP67 according to IEC 60529

Weight
2.3 kg

Material

Housing material
Polyamide
Polycarbonate

Seal material
Fluorocautchouc

Part No.
R412028645

Technical information

The protection class is only ensured when the plug is mounted properly. For detailed information, see operating instructions.

Liquid oil or water must be separated via prefiltering. If it is not separated sufficiently, drifting may result.

Precision - Standard measurement range: ±6% of measured value, + 0.6% of final value- Extended measurement range: ±8% of measured value, + 0.8% of final value

Standard measurement range for flow measurement: compressed air 0.5 ... 100 m/s, extended measurement range: compressed air >100 ... 150 m/s, in accordance with ISO 8778

The pressure dew point must be at least 15 °C under ambient and medium temperature and may not exceed 3 °C .

The oil content of compressed air must remain constant during the life cycle.

Use only the approved oils from AVENTICS. Further information can be found in the "Technical information" document (available in <https://www.emerson.com/en-us/support>).

Dimensions in mm

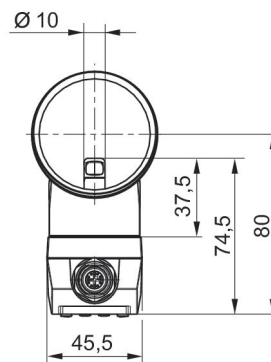
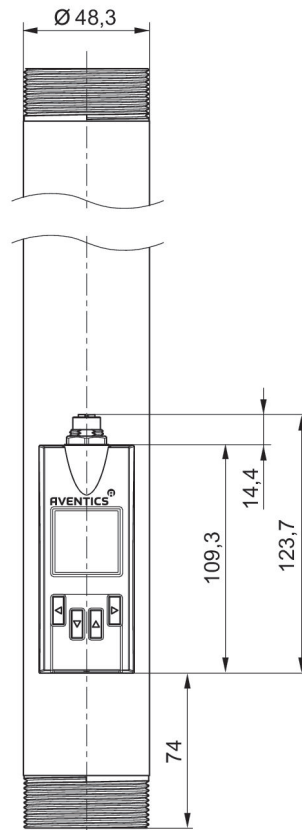
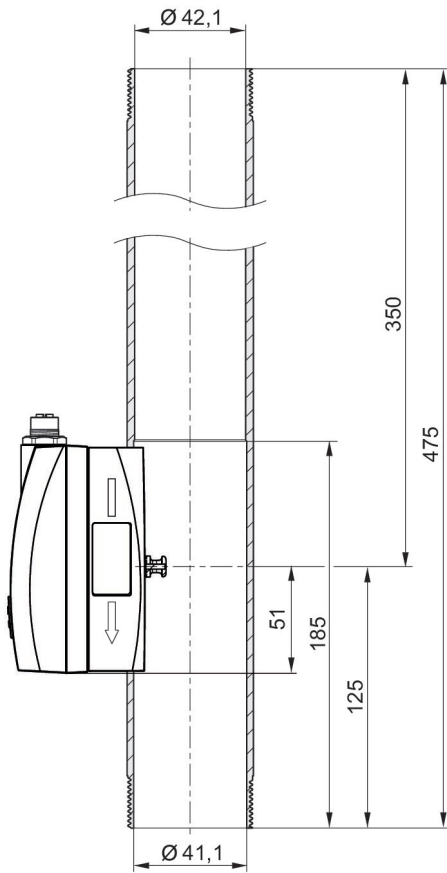

Pin assignments

M12x1 connection, 8-pin (X-coded) Ethernet

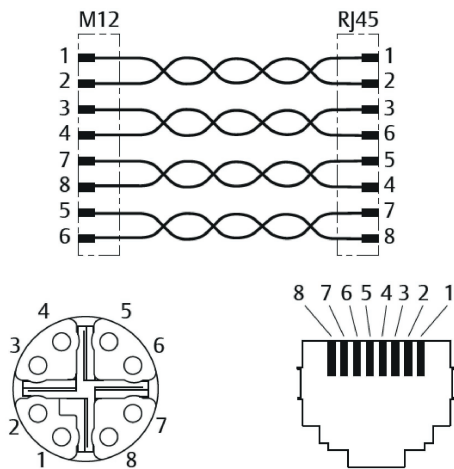

M12 x-coded	RJ45	Color	Function	10/100 Mbit
1	1	WH / OG	TX(+) + POE	TxData +
2	2	OG	TX(-) + POE	TxData -
3	3	WH / GN	RX(+) + POE	RxData +
4	4	GN	RX(-) + POE	RxData -
7	5	WH / BU	POE +	
8	6	BU	POE +	
5	7	WH / BN	POE -	
6	8	BN	POE -	

Flow sensor, Ethernet, Series AF2-HF

R412028647

General series information Series AF2

- The AVENTICS Series AF2 are flow sensors that monitor air consumption in pneumatic systems, enabling rapid intervention in the event of leakage. The Series AF2 helps to optimize energy consumption, prevent machine downtime and cut costs.



Technical data

Industry
Industrial

Switching principle
Flow measuring principle: calorimetric

Protocol
Ethernet

Compressed air connection
R 2

Certificates
CE declaration of conformity
RoHS

Working pressure min.
0 bar

Working pressure max
16 bar

Min. ambient temperature
-20 °C

Max. ambient temperature
60 °C

Min. medium temperature
-20 °C

Max. medium temperature
60 °C

Medium
Compressed air
Argon
Nitrogen
Helium
Carbon dioxide

Display
OLED

Flow display unit
l/sec
l/min
m³/min
m³/h
ft³/s
m³/min

Pressure display unit
bar
psi

Temperature display unit
°C
°F

Electrical connection 2, type
Plug

Electrical connection 2, thread size
M12x1

Electrical connection 2, number of poles
8-pin

Electrical connection 2, coding
X-coded

Power consumption max.
12 W

Operational voltage
24 V DC

Response time
< 0.3 s

Short circuit resistance
short circuit resistant

Shock resistance max.
30 g, 11 ms

Vibration resistance
1 g (10 - 2000 Hz) IEC 60068 - 2-6

Reproducibility
± 1.5% of the measured value

Protection class
IP65
IP67 according to IEC 60529

Weight
2.8 kg

Material

Housing material
Polyamide
Polycarbonate

Seal material
Fluorocaoutchouc

Part No.
R412028647

Technical information

The protection class is only ensured when the plug is mounted properly. For detailed information, see operating instructions.

Liquid oil or water must be separated via prefiltering. If it is not separated sufficiently, drifting may result.

Precision - Standard measurement range: ±6% of measured value, + 0.6% of final value- Extended measurement range: ±8% of measured value, + 0.8% of final value

Standard measurement range for flow measurement: compressed air 0.5 ... 100 m/s, extended measurement range: compressed air >100 ... 150 m/s, in accordance with ISO 8778

The pressure dew point must be at least 15 °C under ambient and medium temperature and may not exceed 3 °C .

The oil content of compressed air must remain constant during the life cycle.

Use only the approved oils from AVENTICS. Further information can be found in the "Technical information" document (available in <https://www.emerson.com/en-us/support>).

Dimensions in mm

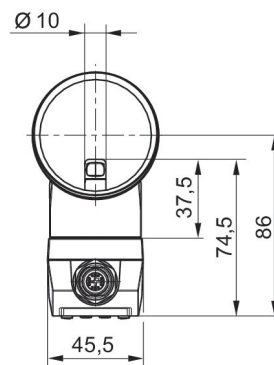
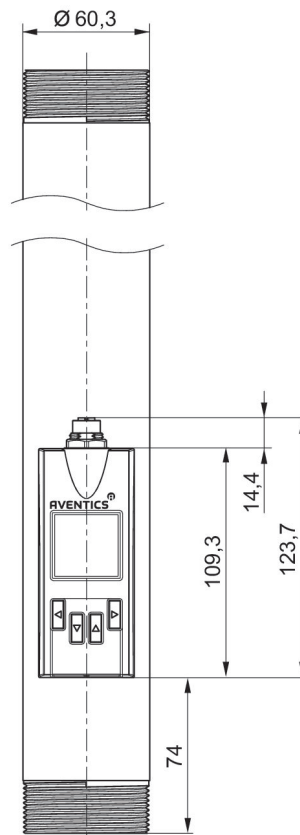
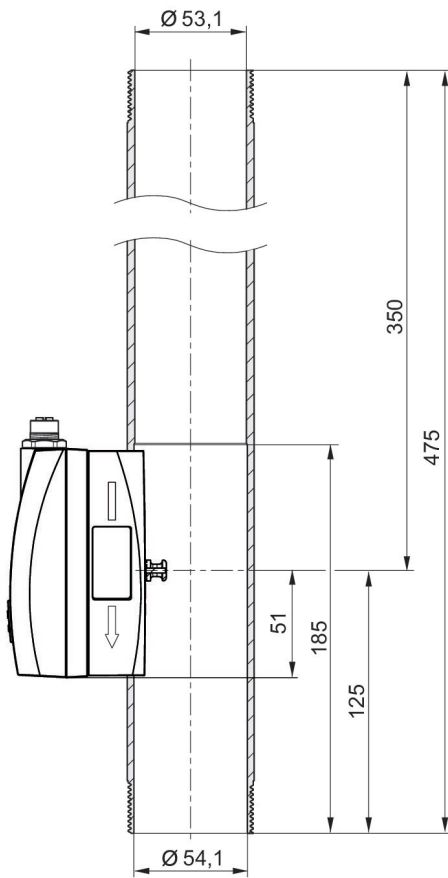

Pin assignments

M12x1 connection, 8-pin (X-coded) Ethernet

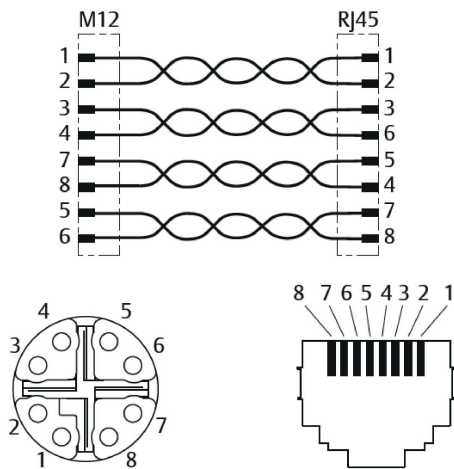

M12 x-coded	RJ45	Color	Function	10/100 Mbit
1	1	WH / OG	TX(+) + POE	TxData +
2	2	OG	TX(-) + POE	TxData -
3	3	WH / GN	RX(+) + POE	RxData +
4	4	GN	RX(-) + POE	RxData -
7	5	WH / BU	POE +	
8	6	BU	POE +	
5	7	WH / BN	POE -	
6	8	BN	POE -	

Flow sensor, Ethernet, Series AF2-HF

R412028649

General series information Series AF2

- The AVENTICS Series AF2 are flow sensors that monitor air consumption in pneumatic systems, enabling rapid intervention in the event of leakage. The Series AF2 helps to optimize energy consumption, prevent machine downtime and cut costs.



Technical data

Industry
Industrial

Switching principle
Flow measuring principle: calorimetric

Protocol
Ethernet

Compressed air connection
R 2" NPT

Certificates
CE declaration of conformity
RoHS

Working pressure min.
0 bar

Working pressure max
16 bar

Min. ambient temperature
-20 °C

Max. ambient temperature
60 °C

Min. medium temperature
-20 °C

Max. medium temperature
60 °C

Medium
Compressed air
Argon
Nitrogen
Helium
Carbon dioxide

Display
OLED

Flow display unit
l/sec
l/min
m³/min
m³/h
ft³/s
m³/min

Pressure display unit
bar
psi

Temperature display unit
°C
°F

Electrical connection 2, type
Plug

Electrical connection 2, thread size
M12x1

Electrical connection 2, number of poles
8-pin

Electrical connection 2, coding
X-coded

Power consumption max.
12 W

Operational voltage
24 V DC

Response time
< 0.3 s

Short circuit resistance
short circuit resistant

Shock resistance max.
30 g, 11 ms

Vibration resistance
1 g (10 - 2000 Hz) IEC 60068 - 2-6

Reproducibility
± 1.5% of the measured value

Protection class
IP65
IP67 according to IEC 60529

Weight
2.8 kg

Material

Housing material
Polyamide
Polycarbonate

Seal material
Fluorocaoutchouc

Part No.
R412028649

Technical information

The protection class is only ensured when the plug is mounted properly. For detailed information, see operating instructions.

Liquid oil or water must be separated via prefiltering. If it is not separated sufficiently, drifting may result.

Precision - Standard measurement range: ±6% of measured value, + 0.6% of final value- Extended measurement range: ±8% of measured value, + 0.8% of final value

Standard measurement range for flow measurement: compressed air 0.5 ... 100 m/s, extended measurement range: compressed air >100 ... 150 m/s, in accordance with ISO 8778

The pressure dew point must be at least 15 °C under ambient and medium temperature and may not exceed 3 °C .

The oil content of compressed air must remain constant during the life cycle.

Use only the approved oils from AVENTICS. Further information can be found in the "Technical information" document (available in <https://www.emerson.com/en-us/support>).

Dimensions in mm

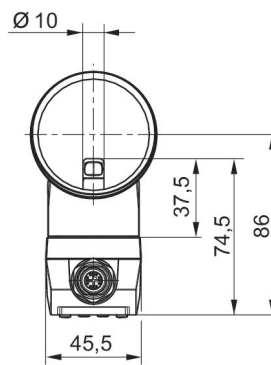
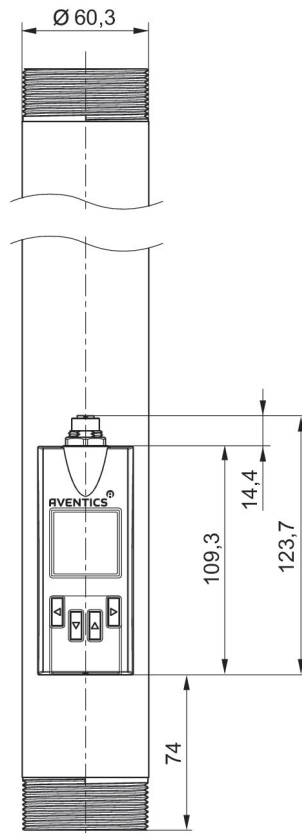
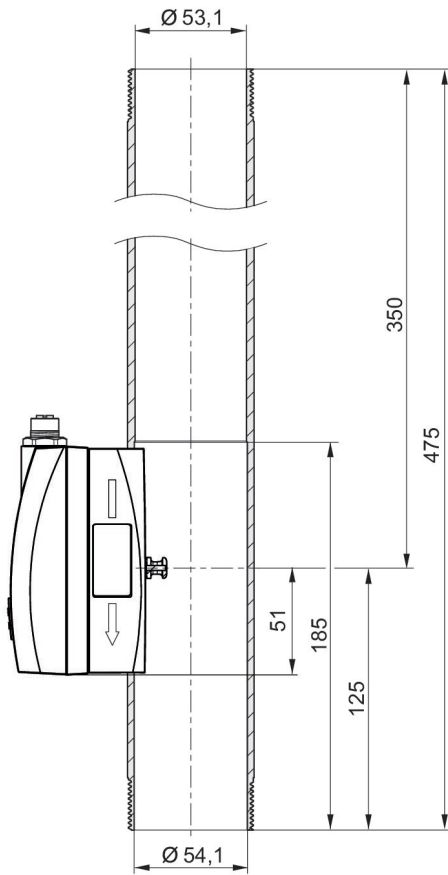

Pin assignments

M12x1 connection, 8-pin (X-coded) Ethernet

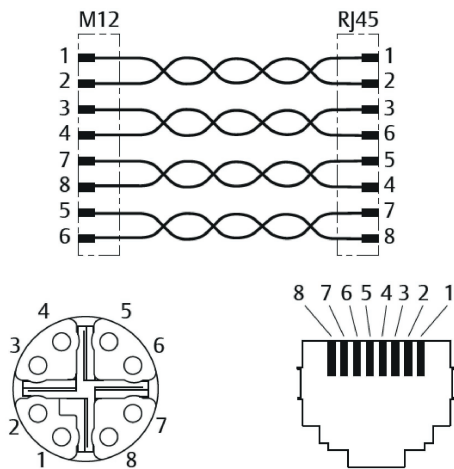

M12 x-coded	RJ45	Color	Function	10/100 Mbit
1	1	WH / OG	TX(+) + POE	TxData +
2	2	OG	TX(-) + POE	TxData -
3	3	WH / GN	RX(+) + POE	RxData +
4	4	GN	RX(-) + POE	RxData -
7	5	WH / BU	POE +	
8	6	BU	POE +	
5	7	WH / BN	POE -	
6	8	BN	POE -	

Flow sensor, IO-Link, Series AF2-HF

R412028642

General series information Series AF2

- The AVENTICS Series AF2 are flow sensors that monitor air consumption in pneumatic systems, enabling rapid intervention in the event of leakage. The Series AF2 helps to optimize energy consumption, prevent machine downtime and cut costs.



Technical data

Industry
Industrial

Frame size
DN40

Switching principle
Flow measuring principle: calorimetric

Protocol
IO-Link

Compressed air connection
R 1 1/2

Certificates
CE declaration of conformity
RoHS

Working pressure min.
0 bar

Working pressure max
16 bar

Min. ambient temperature
-20 °C

Max. ambient temperature
60 °C

Min. medium temperature
-20 °C

Max. medium temperature
60 °C

Medium
Compressed air
Argon
Nitrogen
Helium
Carbon dioxide

Display
OLED

Flow display unit
l/sec
l/min
m³/min
m³/h
ft³/s
m³/min

Pressure display unit
bar
psi

Temperature display unit
°C
°F

Electrical connection 2, type
Plug

Electrical connection 2, thread size
M12x1

Electrical connection 2, number of poles
5-pin

Electrical connection 2, coding
A-coded

Power consumption max.
12 W

Operational voltage
24 V DC

Response time
< 0.3 s

Short circuit resistance
short circuit resistant

Shock resistance max.
30 g, 11 ms

Vibration resistance
1 g (10 - 2000 Hz) IEC 60068 - 2-6

Reproducibility
± 1.5% of the measured value

Protection class
IP65

IP67 according to IEC 60529

Weight
2.3 kg

Material

Housing material
Polyamide
Polycarbonate

Seal material
Fluorocautchouc

Part No.
R412028642

Technical information

The protection class is only ensured when the plug is mounted properly. For detailed information, see operating instructions.

Liquid oil or water must be separated via prefiltering. If it is not separated sufficiently, drifting may result.

Precision - Standard measurement range: ±6% of measured value, + 0.6% of final value- Extended measurement range: ±8% of measured value, + 0.8% of final value

Standard measurement range for flow measurement: compressed air 0.5 ... 100 m/s, extended measurement range: compressed air >100 ... 150 m/s, in accordance with ISO 8778

The pressure dew point must be at least 15 °C under ambient and medium temperature and may not exceed 3 °C .

The oil content of compressed air must remain constant during the life cycle.

Use only the approved oils from AVENTICS. Further information can be found in the "Technical information" document (available in <https://www.emerson.com/en-us/support>).

Dimensions in mm

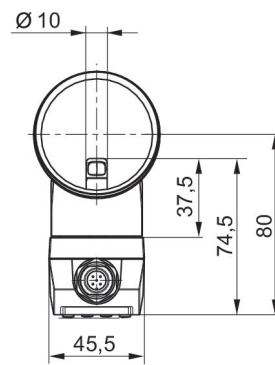
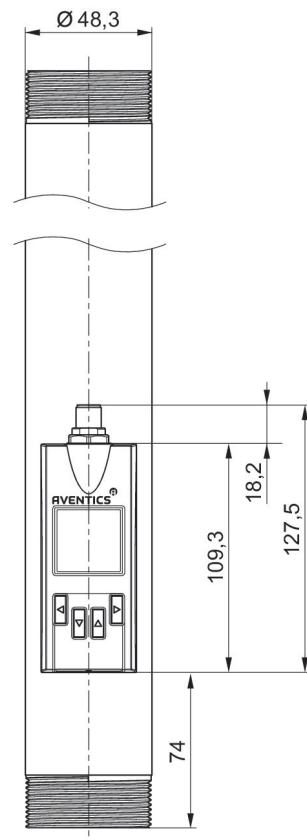
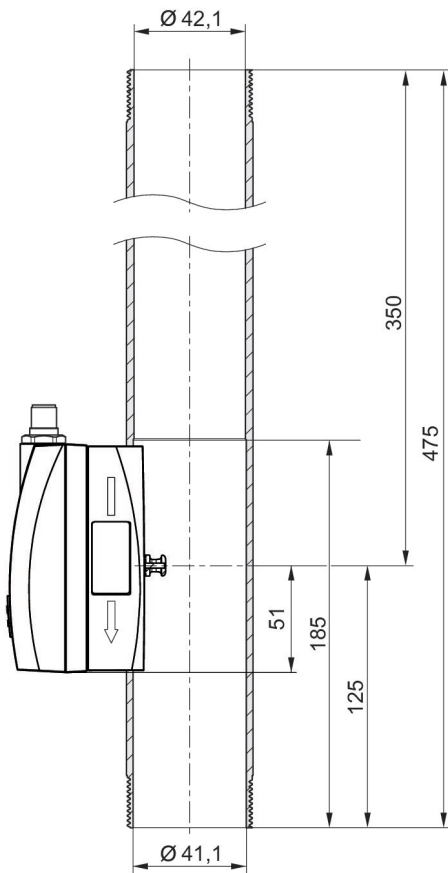

Pin assignments

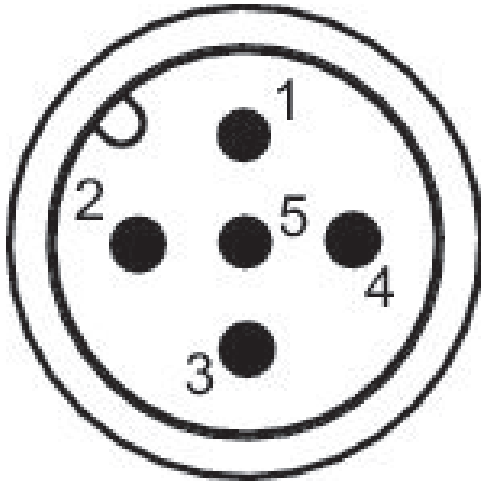

Pin assignments

Pin	Allocation	Wire color
1	L+ Supply Voltage	brown
2	QA (output 4 ... 20 mA)	white
3	m = mass	blue
4	C/Q1 (IO-Link/switch output)	black
5	Analog output 4 ... 20 mA	yellow

Flow sensor, IO-Link, Series AF2-HF

R412028644

General series information Series AF2

- The AVENTICS Series AF2 are flow sensors that monitor air consumption in pneumatic systems, enabling rapid intervention in the event of leakage. The Series AF2 helps to optimize energy consumption, prevent machine downtime and cut costs.



Technical data

Industry
Industrial

Frame size
DN40

Switching principle
Flow measuring principle: calorimetric

Protocol
IO-Link

Compressed air connection
1 1/2" NPT

Certificates
CE declaration of conformity
RoHS

Working pressure min.
0 bar

Working pressure max
16 bar

Min. ambient temperature
-20 °C

Max. ambient temperature
60 °C

Min. medium temperature
-20 °C

Max. medium temperature
60 °C

Medium
Compressed air
Argon
Nitrogen
Helium
Carbon dioxide

Display
OLED

Flow display unit
l/sec
l/min
m³/min
m³/h
ft³/s
m³/min

Pressure display unit
bar
psi

Temperature display unit
°C
°F

Electrical connection 2, type
Plug

Electrical connection 2, thread size
M12x1

Electrical connection 2, number of poles
5-pin

Electrical connection 2, coding
A-coded

Power consumption max.
12 W

Operational voltage
24 V DC

Response time
< 0.3 s

Short circuit resistance
short circuit resistant

Shock resistance max.
30 g, 11 ms

Vibration resistance
1 g (10 - 2000 Hz) IEC 60068 - 2-6

Reproducibility
± 1.5% of the measured value

Protection class
IP65

IP67 according to IEC 60529

Weight
2.3 kg

Material

Housing material
Polyamide
Polycarbonate

Seal material
Fluorocautchouc

Part No.
R412028644

Technical information

The protection class is only ensured when the plug is mounted properly. For detailed information, see operating instructions.

Liquid oil or water must be separated via prefiltering. If it is not separated sufficiently, drifting may result.

Precision - Standard measurement range: ±6% of measured value, + 0.6% of final value- Extended measurement range: ±8% of measured value, + 0.8% of final value

Standard measurement range for flow measurement: compressed air 0.5 ... 100 m/s, extended measurement range: compressed air >100 ... 150 m/s, in accordance with ISO 8778

The pressure dew point must be at least 15 °C under ambient and medium temperature and may not exceed 3 °C .

The oil content of compressed air must remain constant during the life cycle.

Use only the approved oils from AVENTICS. Further information can be found in the "Technical information" document (available in <https://www.emerson.com/en-us/support>).

Dimensions in mm

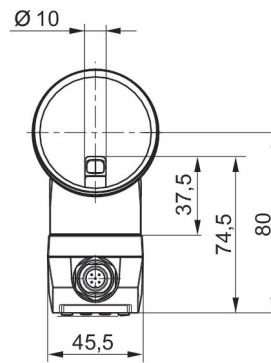
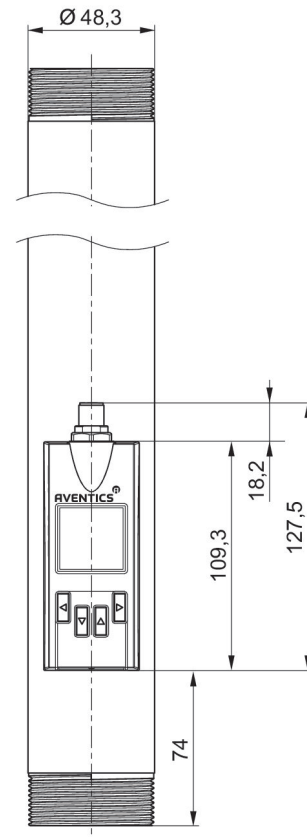
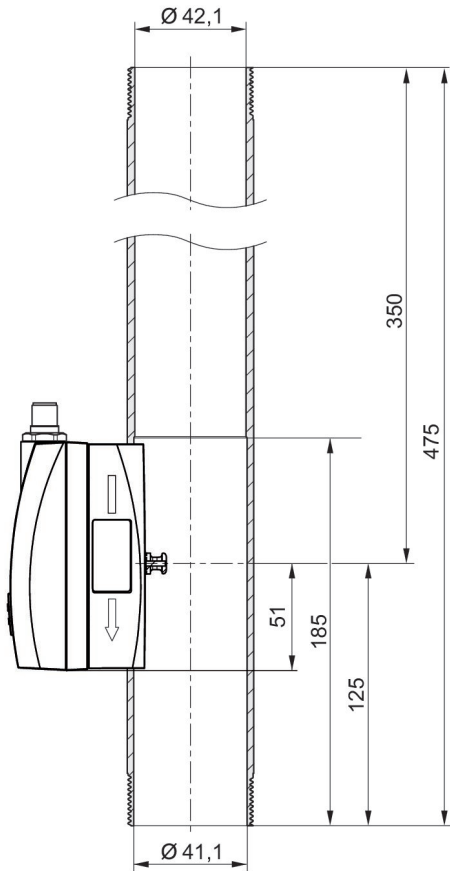

Pin assignments

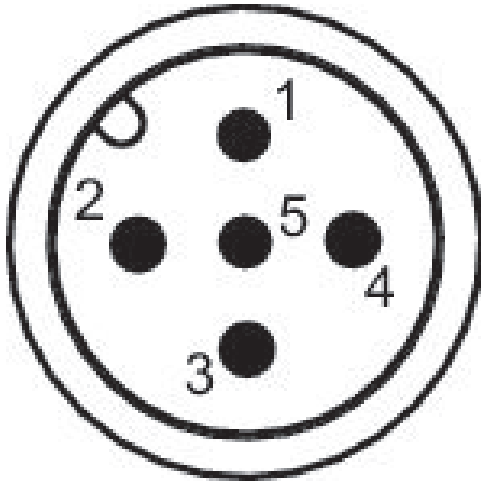

Pin assignments

Pin	Allocation	Wire color
1	L+ Supply Voltage	brown
2	QA (output 4 ... 20 mA)	white
3	m = mass	blue
4	C/Q1 (IO-Link/switch output)	black
5	Analog output 4 ... 20 mA	yellow

Flow sensor, IO-Link, Series AF2-HF

R412028646

General series information Series AF2

- The AVENTICS Series AF2 are flow sensors that monitor air consumption in pneumatic systems, enabling rapid intervention in the event of leakage. The Series AF2 helps to optimize energy consumption, prevent machine downtime and cut costs.



Technical data

Industry
Industrial

Switching principle
Flow measuring principle: calorimetric

Protocol
IO-Link

Compressed air connection
R 2

Certificates
CE declaration of conformity
RoHS

Working pressure min.
0 bar

Working pressure max
16 bar

Min. ambient temperature
-20 °C

Max. ambient temperature
60 °C

Min. medium temperature
-20 °C

Max. medium temperature
60 °C

Medium
Compressed air
Argon
Nitrogen
Helium
Carbon dioxide

Display
OLED

Flow display unit
l/sec
l/min
m³/min
m³/h
ft³/s
m³/min

Pressure display unit
bar
psi

Temperature display unit
°C
°F

Electrical connection 2, type
Plug

Electrical connection 2, thread size
M12x1

Electrical connection 2, number of poles
5-pin
Electrical connection 2, coding
A-coded
Power consumption max.
12 W
Operational voltage
24 V DC
Response time
< 0.3 s
Short circuit resistance
short circuit resistant

Shock resistance max.
30 g, 11 ms
Vibration resistance
1 g (10 - 2000 Hz) IEC 60068 - 2-6
Reproducibility
± 1.5% of the measured value
Protection class
IP65
IP67 according to IEC 60529
Weight
2.8 kg

Material

Housing material
Polyamide
Polycarbonate

Seal material
Fluorocaoutchouc
Part No.
R412028646

Technical information

The protection class is only ensured when the plug is mounted properly. For detailed information, see operating instructions.

Liquid oil or water must be separated via prefiltering. If it is not separated sufficiently, drifting may result.

Precision - Standard measurement range: ±6% of measured value, + 0.6% of final value- Extended measurement range: ±8% of measured value, + 0.8% of final value

Standard measurement range for flow measurement: compressed air 0.5 ... 100 m/s, extended measurement range: compressed air >100 ... 150 m/s, in accordance with ISO 8778

The pressure dew point must be at least 15 °C under ambient and medium temperature and may not exceed 3 °C .

The oil content of compressed air must remain constant during the life cycle.

Use only the approved oils from AVENTICS. Further information can be found in the "Technical information" document (available in <https://www.emerson.com/en-us/support>).

Dimensions in mm

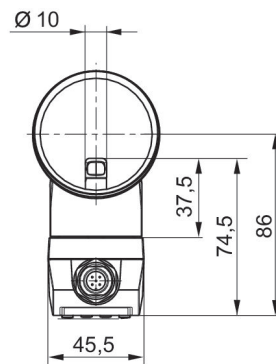
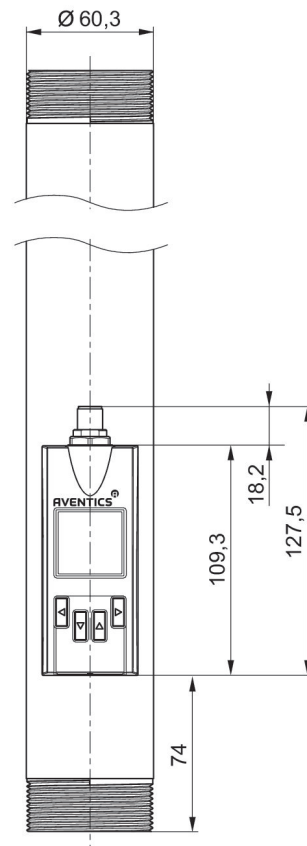
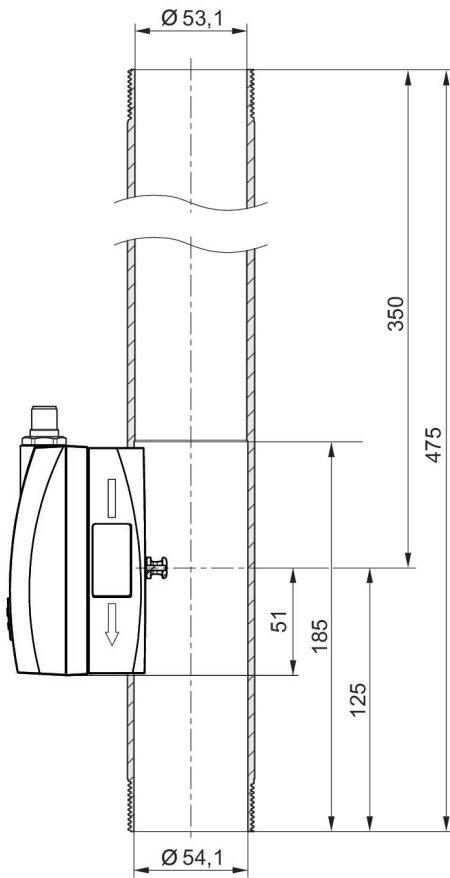

Pin assignments

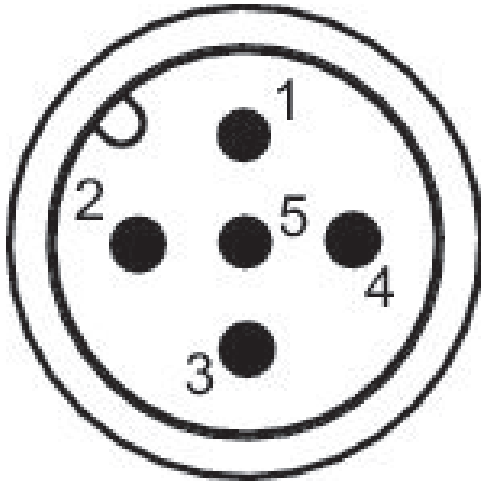

Pin assignments

Pin	Allocation	Wire color
1	L+ Supply Voltage	brown
2	QA (output 4 ... 20 mA)	white
3	m = mass	blue
4	C/Q1 (IO-Link/switch output)	black
5	Analog output 4 ... 20 mA	yellow

Flow sensor, IO-Link, Series AF2-HF

R412028648

General series information Series AF2

- The AVENTICS Series AF2 are flow sensors that monitor air consumption in pneumatic systems, enabling rapid intervention in the event of leakage. The Series AF2 helps to optimize energy consumption, prevent machine downtime and cut costs.



Technical data

Industry
Industrial

Switching principle
Flow measuring principle: calorimetric

Protocol
IO-Link

Compressed air connection
R 2" NPT

Certificates
CE declaration of conformity
RoHS

Working pressure min.
0 bar

Working pressure max
16 bar

Min. ambient temperature
-20 °C

Max. ambient temperature
60 °C

Min. medium temperature
-20 °C

Max. medium temperature
60 °C

Medium
Compressed air
Argon
Nitrogen
Helium
Carbon dioxide

Display
OLED

Flow display unit
l/sec
l/min
m³/min
m³/h
ft³/s
m³/min

Pressure display unit
bar
psi

Temperature display unit
°C
°F

Electrical connection 2, type
Plug

Electrical connection 2, thread size
M12x1

Electrical connection 2, number of poles
5-pin
Electrical connection 2, coding
A-coded
Power consumption max.
12 W
Operational voltage
24 V DC
Response time
< 0.3 s
Short circuit resistance
short circuit resistant

Shock resistance max.
30 g, 11 ms
Vibration resistance
1 g (10 - 2000 Hz) IEC 60068 - 2-6
Reproducibility
± 1.5% of the measured value
Protection class
IP65
IP67 according to IEC 60529
Weight
2.8 kg

Material

Housing material
Polyamide
Polycarbonate

Seal material
Fluorocaoutchouc
Part No.
R412028648

Technical information

The protection class is only ensured when the plug is mounted properly. For detailed information, see operating instructions.

Liquid oil or water must be separated via prefiltering. If it is not separated sufficiently, drifting may result.

Precision - Standard measurement range: ±6% of measured value, + 0.6% of final value- Extended measurement range: ±8% of measured value, + 0.8% of final value

Standard measurement range for flow measurement: compressed air 0.5 ... 100 m/s, extended measurement range: compressed air >100 ... 150 m/s, in accordance with ISO 8778

The pressure dew point must be at least 15 °C under ambient and medium temperature and may not exceed 3 °C .

The oil content of compressed air must remain constant during the life cycle.

Use only the approved oils from AVENTICS. Further information can be found in the "Technical information" document (available in <https://www.emerson.com/en-us/support>).

Dimensions in mm

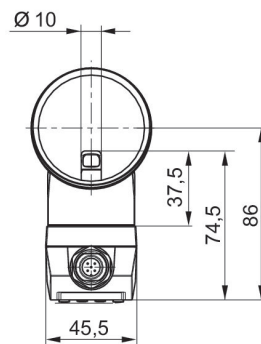
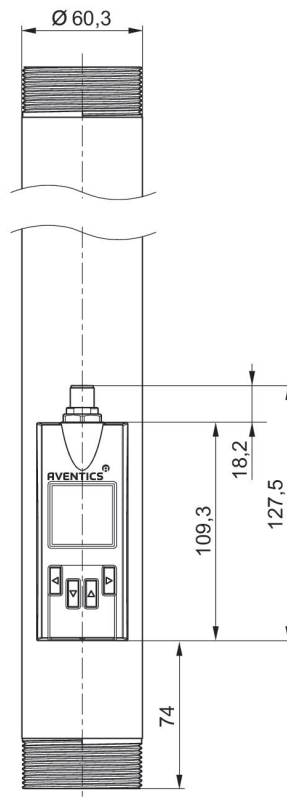
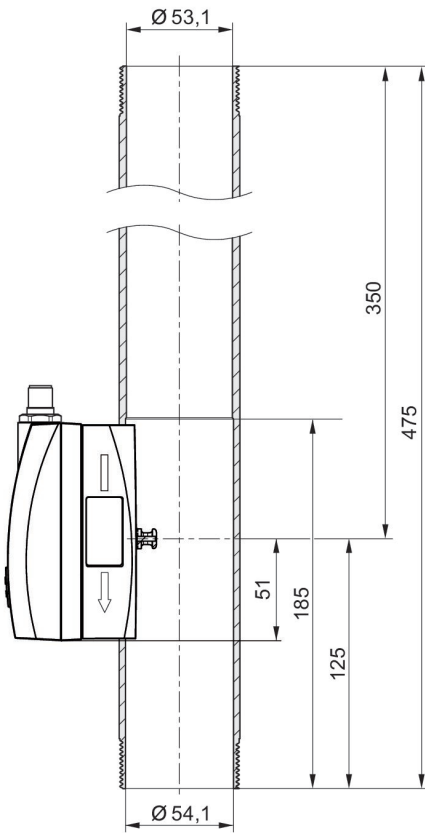

Pin assignments

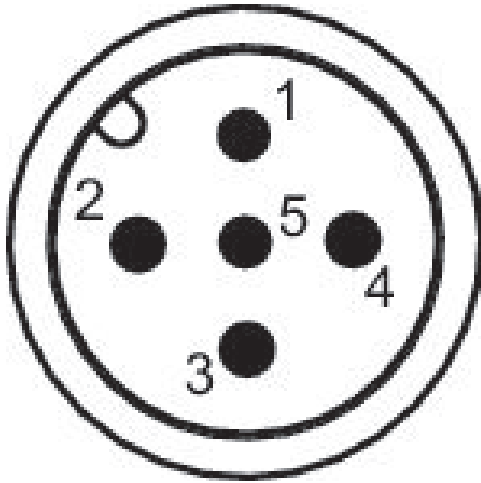

Pin assignments

Pin	Allocation	Wire color
1	L+ Supply Voltage	brown
2	QA (output 4 ... 20 mA)	white
3	m = mass	blue
4	C/Q1 (IO-Link/switch output)	black
5	Analog output 4 ... 20 mA	yellow

Round plug connector, Series CON-RD

- Socket M12x1 5-pin A-coded angled 90°
- open cable ends
- with cable
- shielded



Ambient temperature min./max.	-25 ... 80 °C
Operational voltage	48 V AC/DC
Protection class	IP67
Wire cross-section	0.34 mm ²
Weight	See table below

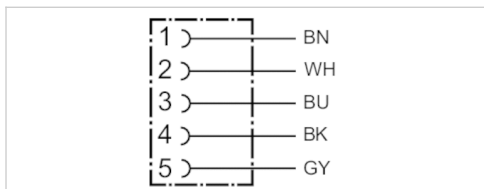

Technical data

Part No.	Max. current	Number of wires	Cable-Ø	Cable length	Weight
R419800109	4 A	5	6 mm	2.5 m	0.145 kg
R419800110	4 A	5	6 mm	5 m	0.27 kg
R419800546	4 A	5	6 mm	10 m	0.514 kg

Technical information

Material	
Housing	Thermoplastic elastomer
Cable sheath	Polyurethane

Dimensions

Dimensions

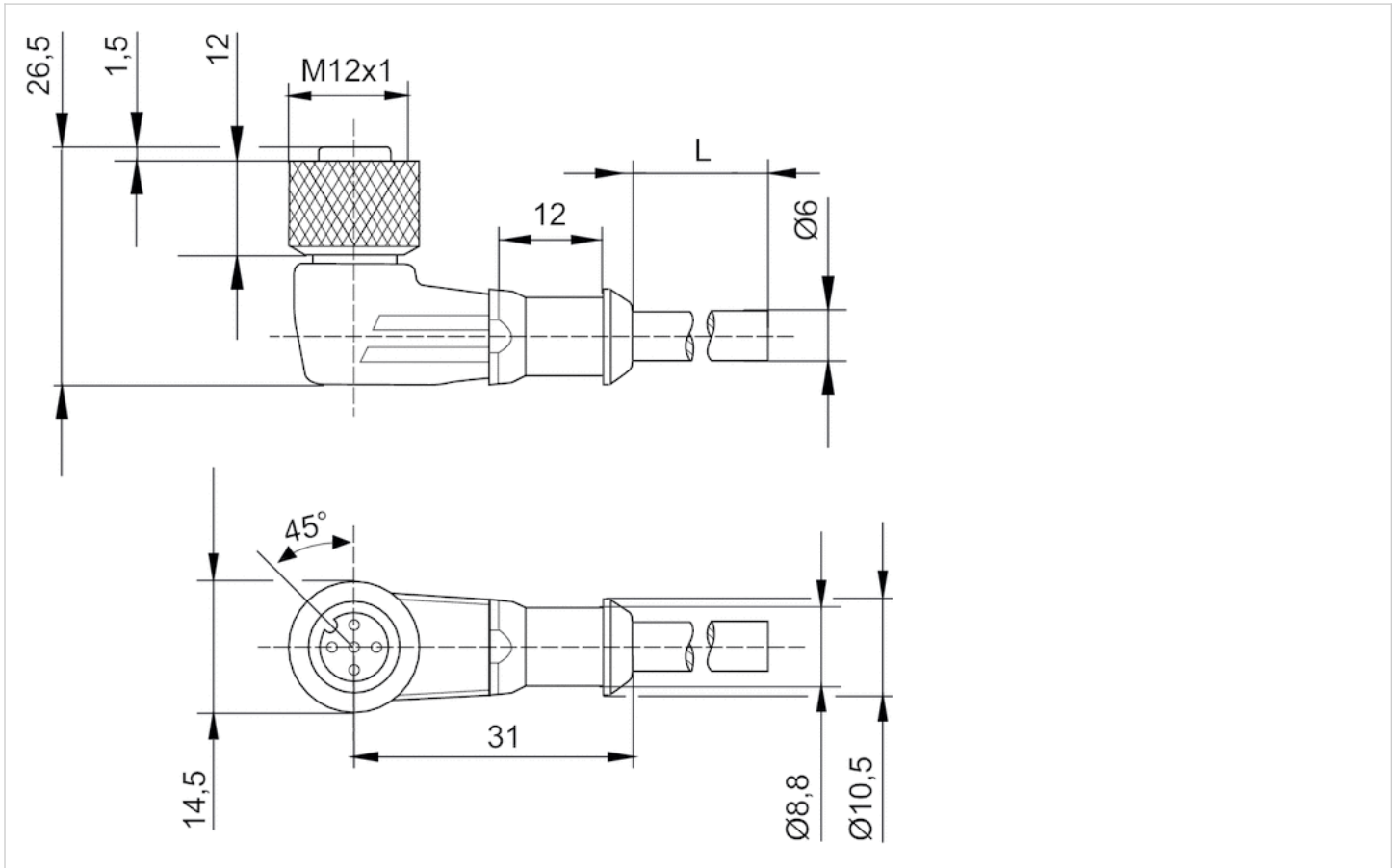

L = length

Pin assignments

Pin assignment, socket

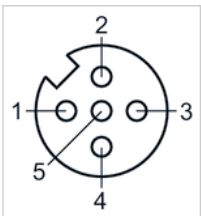

- (1) BN=brown
- (2) WH=white
- (3) BU=blue
- (4) BK=black
- (5) GY=grey

Round plug connectors with cable, Series CON-RD

- Plug M12x1 8-pin X-coded angled 90°
- Plug RJ45 8-pin X-coded straight
- shielded



Ambient temperature min./max.	-25 ... 85 °C
Protection class	IP66K
Wire cross-section	0.14 mm ²

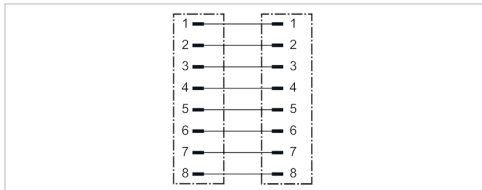

Technical data

Part No.	Max. current	Cable length
R412027647	0.5 A	5 m

Technical information

Material	
Cable sheath	Polyurethane

Dimensions

Dimensions

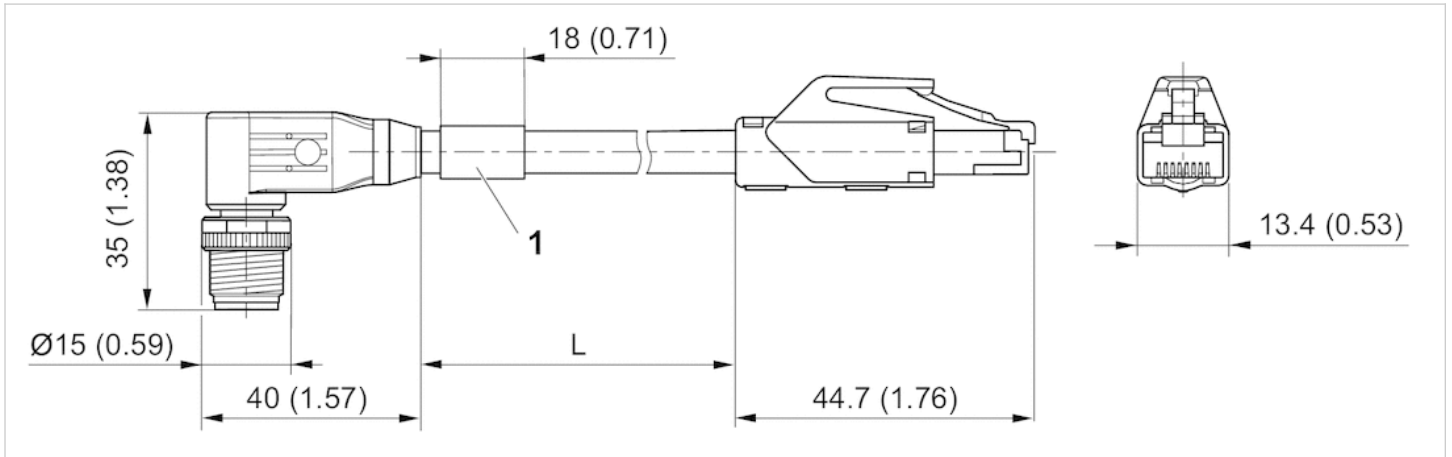

1) Name plate

Pin assignments

Plug pin assignment

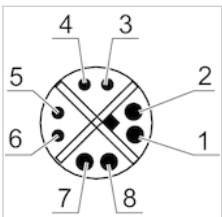

Plug pin assignment

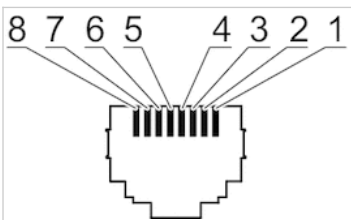

Efficient pneumatic solutions, our program: cylinders and drives, valves and valve systems, air supply management



Visit us: [Emerson.com/Aventics](https://www.emerson.com/Aventics)

Your local contact: [Emerson.com/contactus](https://www.emerson.com/contactus)



[Emerson.com](https://www.emerson.com)



[Facebook.com/EmersonAutomationSolutions](https://www.facebook.com/EmersonAutomationSolutions)



[LinkedIn.com/company/Emerson-Automation-Solutions](https://www.linkedin.com/company/Emerson-Automation-Solutions)



[Twitter.com/EMR_Automation](https://twitter.com/EMR_Automation)

An example configuration is depicted on the title page. The delivered product may thus vary from that in the illustration. Subject to change. This Document, as well as the data, specifications and other information set forth in it, are the exclusive property of AVENTICS GmbH. It may not be reproduced or given to third parties without its consent. Only use the AVENTICS products shown in industrial applications. Read the product documentation completely and carefully before using the product. Observe the applicable regulations and laws of the respective country. When integrating the product into applications, note the system manufacturer's specifications for safe use of the product. The data specified only serve to describe the product. No statements concerning a certain condition or suitability for a certain application can be derived from our information. The information given does not release the user from the obligation of own judgment and verification. It must be remembered that the products are subject to a natural process of wear and aging.

The Emerson logo is a trademark and service mark of Emerson Electric Co. Brand logotype are registered trademarks of one of the Emerson family of companies. All other marks are the property of their respective owners. © 2017 Emerson Electric Co. All rights reserved.
2019-03



CONSIDER IT SOLVED™